

**F282xA**  
**FOM II Series**  
**Fiber Optic Modem**  
**Technical Manual**

**RS-530 / MIL-STD-188-114**

September 2001

Copyright September 2001

VERSITRON, Inc.  
83 Albe Drive / Suite C  
Newark, DE 19702  
[www.versitron.com](http://www.versitron.com)

A010930390

## **PROPRIETARY DATA**

All data in this manual is proprietary and may not be disclosed, used or duplicated, for procurement or manufacturing purposes, without prior written permission by  
**VERSITRON, Inc.**

## **WARRANTY**

All VERSITRON products purchased after January 2001 include a limited lifetime warranty against defects in materials and workmanship for the lifetime of the product. Purchases made prior to January 2001 are warranted for a period of one year from date of delivery. VERSITRON reserves the right to repair or, at our option, replace parts which during normal usage prove to be defective during the warranty period provided that:

1. You call VERSITRON at (302) 894-0699 or (800) 537-2296 and obtain a Return Maintenance Authorization (RMA) Number. Please reference your RMA number on the outside of the shipping box.
2. Shipping charges are pre-paid.

No other warranty is expressed or implied and we are not liable for consequential damages. For repairs outside of the warranty period, the same procedure must be followed.

## TABLE OF CONTENTS

PARAGRAPH	TITLE	PAGE
<b>SECTION 1: DESCRIPTION OF EQUIPMENT</b>		
1.1	INTRODUCTION .....	1
1.2	DESCRIPTION OF EQUIPMENT.....	1
1.2.1	Functional Characteristics .....	1
1.2.2	Physical Characteristics.....	1
1.3	SPECIFICATIONS.....	5
<b>SECTION 2: INSTALLATION</b>		
2.1	GENERAL .....	6
2.2	SITE SELECTION AND MOUNTING.....	6
2.3	POWER REQUIREMENTS.....	6
2.4	SWITCH SETTINGS .....	6
2.5	TIMING MODE.....	8
2.5.1	Source Timing .....	8
2.5.2	Terminal Timing.....	8
2.6	LOOPBACK.....	8
2.6.1	Fiber/Copper Loopback.....	8
2.7	INITIAL CHECKOUT PROCEDURE.....	9
<b>SECTION 3: OPERATION</b>		
3.1	INTRODUCTION .....	10
3.2	STATUS INDICATORS/AUDIBLE ALARM.....	10
3.3	OPERATING CONTROLS .....	10
<b>SECTION 4: THEORY OF OPERATION</b>		
4.1	INTRODUCTION .....	11
<b>SECTION 5: MAINTENANCE AND TROUBLESHOOTING</b>		
5.1	INTRODUCTION .....	12
5.2	FAULT ISOLATION.....	12

## LIST OF ILLUSTRATIONS

FIGURE	TITLE	PAGE
1.	OVERALL VIEW .....	2
2.	INTERFACE EXTENDER CONFIGURATION .....	2
3.	MODEM LINK CONFIGURATION .....	3
4.	MULTIPLEXER CONFIGURATION .....	3
5.	SWITCH SETTINGS .....	7

## LIST OF TABLES

TABLE	TITLE	PAGE
1.	ENCLOSURES / CHASSIS.....	4
2.	TERMINAL AND SOURCE TIMING SWITCH SETTINGS .....	7
3.	SWITCH SETTINGS .....	7
4.	NON-OPERATIONAL INDICATORS.....	12

# SECTION 1 DESCRIPTION OF EQUIPMENT

## 1.1 INTRODUCTION

This manual provides information on the installation and operation of the Model F282xA FOM II Series Fiber Optic Modem. Section 1 contains a general description of the equipment. Section 2 contains installation instructions. Section 3 contains operating instructions. Section 4 provides the theory of operation. Section 5 contains maintenance and troubleshooting information. Figure 1 is an overall view of the F282xA.

<b>Model Number</b>	<b>Part Number</b>	<b>Description</b>
F2822A	30390-02	RS-530 or MIL-STD-188-114, MM, 850nm optics, ST connectors, 2 Km operational distance.
F2824A	30390-04	RS-530 or MIL-STD-188-114, MM, 1300nm optics, ST connectors, 8 Km operational distance.
F2825A	30390-05	RS-530 or MIL-STD-188-114, SM, 1300nm optics, ST connectors, 14 Km operational distance.

## 1.2 DESCRIPTION OF EQUIPMENT

### 1.2.1 Functional Characteristics

F282xA modems are designed to provide fiber optic links as interface extenders (Figure 2), modem links (Figure 3) or four channel multiplexers (Figure 4) for synchronous, asynchronous or isochronous data. Units are DTE/DCE switch selectable. F282xA Modems use fiber optic cable up to 2km (1.25mi/6,600ft) with multimode 850nm optics, up to 8km (5mi/26,400ft) with multimode 1300nm optics, or 14km (8.7mi/46,000ft) with single mode 1300nm optics. The link is fully transparent in both directions providing full-duplex, half-duplex, or simplex data transmission from 20 Bps to 300 Kbps with terminal timing or 20 Bps to 150 Kbps with source timing. The fiber optic circuit consists of two units connected by fiber optic cable and has data rates and electrical signal characteristics that conform to EIA RS-530 and MIL-STD-188-114 standards. This is accomplished by multiplexing the control signals along with clock and data signals and transmitting the combined signal to the remote unit. At the remote end the combined signal is demultiplexed and applied to the interface.

### 1.2.2 Physical Characteristics

The F282xA circuit card measures 7 x .9 x 11.8in. (WxHxL) and is designed to be mounted in VERSITRON enclosures or chassis (Table 1). Four housing options are available. HF-1 or HF-2 enclosures are available for single or dual card standalone applications. HF-2SS or HF-20 chassis are available for 2-slot or 20-slot 19" rack mount applications. Each modem installed in an HF-1, HF-2 or HF-2SS requires an AC/DC power adapter. Each modem installed in an HF-20 chassis is powered by the AC150W power supply. Two AC150W power supplies are recommended for redundancy. The F282xA has seven indicators: power (PWR), alarm (ALM), transmit data (TXD), receive data (RXD), transmit clock (TXC), receive clock (RXC) and loopback (LB).

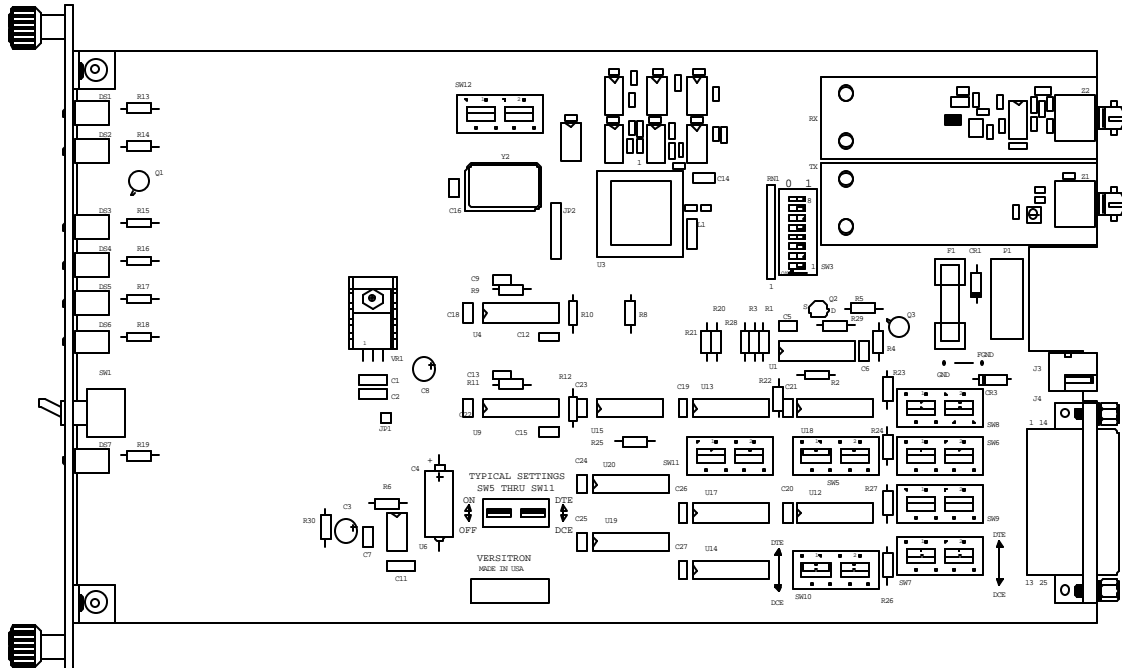

**FIGURE 1. OVERALL VIEW, F282xA MODEMS**

Transmit Data +	< ---	2	2	< ---	Transmit Data +
Transmit Data -	< ---	14	14	< ---	Transmit Data -
Request to Send +	< ---	4	4	< ---	Request to Send +
Request to Send -	< ---	19	19	< ---	Request to Send -
Data Terminal Ready +	< ---	20	20	< ---	Data Terminal Ready +
Data Terminal Ready -	< ---	23	23	< ---	Data Terminal Ready -
Transmit Clock (TT) +	< ---	24	24	< ---	Transmit Clock (TT) +
Transmit Clock (TT) -	< ---	11	11	< ---	Transmit Clock (TT) -
Receive Data +	--- >	3	3	--- >	Receive Data +
Receive Data -	--- >	16	16	--- >	Receive Data -
Clear to Send +	--- >	5	5	--- >	Clear to Send +
Clear to Send -	--- >	13	13	--- >	Clear to Send -
Data Set Ready +	--- >	6	6	--- >	Data Set Ready +
Data Set Ready -	--- >	22	22	--- >	Data Set Ready -
Signal Ground	----	7	7	----	Signal Ground
Carrier Detect +	--- >	8	8	--- >	Carrier Detect +
Carrier Detect -	--- >	10	10	--- >	Carrier Detect -
Transmit Clock +	--- >	15	15	--- >	Transmit Clock +
Transmit Clock -	--- >	12	12	--- >	Transmit Clock -
Receive Clock +	--- >	17	17	--- >	Receive Clock +
Receive Clock -	--- >	9	9	--- >	Receive Clock -
Local Loopback	< ---	18	18	< ---	Local Loopback
Remote Loopback	< ---	21	21	< ---	Remote Loopback
Test Mode	--- >	25	25	--- >	Test Mode
Frame Ground	----	1	1	----	Frame Ground
			<----->		
		fiber cable			
<b>LOCAL MODEM</b>		<b>DTE</b>		<b>DCE</b>	<b>REMOTE MODEM</b>

**FIGURE 2. INTERFACE EXTENDER CONFIGURATION**

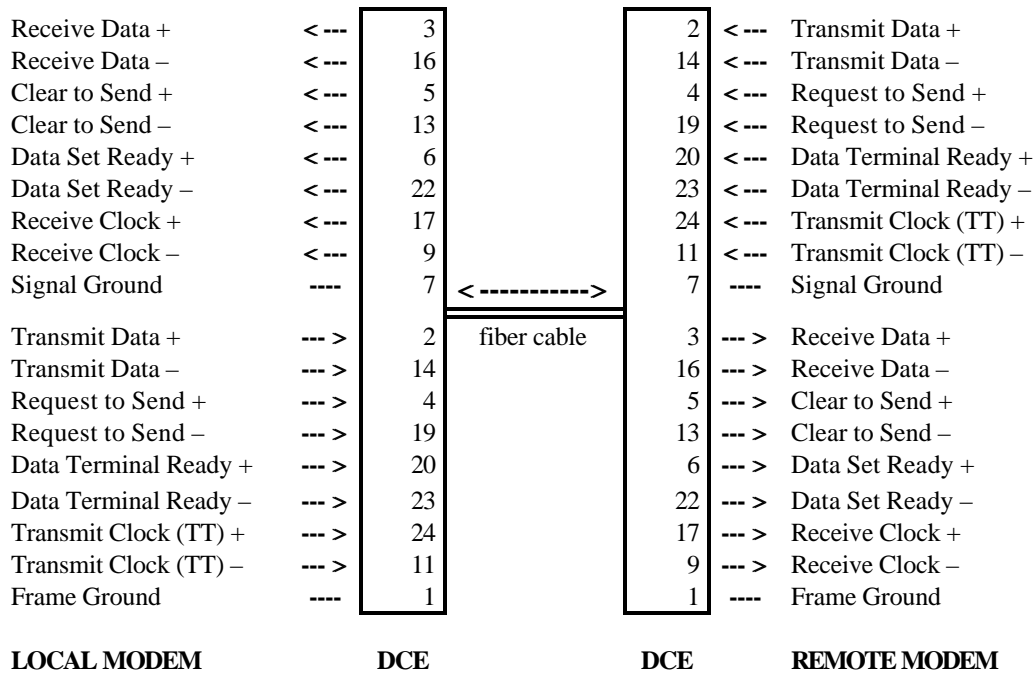

**FIGURE 3. MODEM LINK CONFIGURATION**

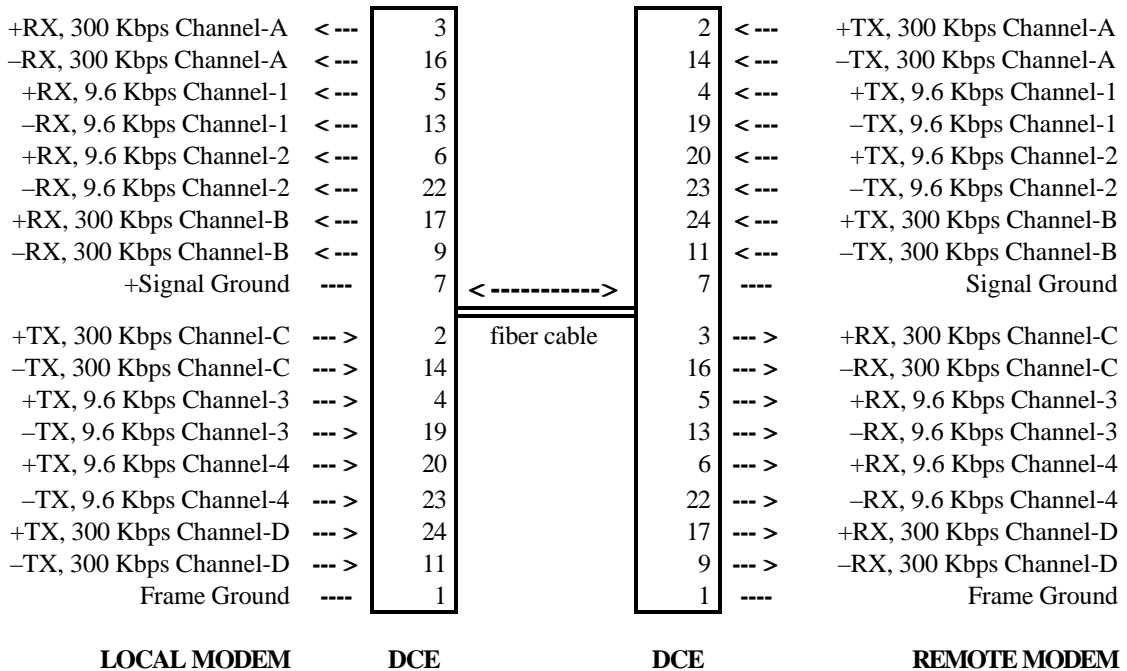

**FIGURE 4. MULTIPLEXER CONFIGURATION**

Model # (Part #)	Dimensions	Description	Power Supply Required* <sup>1</sup>
<b>HF-1</b> (19052)	7.1" W x 1.3" H x 11.6" L	Single Card Desktop Enclosure	<b>PSAC08</b> <b>PSAC09</b> (LTWPD1210PLX) (LTWPD1210EPL)
<b>HF-2*<sup>2</sup></b> (19053)	7.1" W x 2.3" H x 11.6" L	Dual Card Desktop Enclosure	<b>PSAC08</b> <b>PSAC09</b> (LTWPD1210PLX) (LTWPD1210EPL)
<b>HF-2SS*<sup>2</sup></b> (19629)	19" W x 1.7" H x 13.8" L	2-Slot Rack Mount Chassis	<b>PSAC08</b> <b>PSAC09</b> (LTWPD1210PLX) (LTWPD1210EPL)
<b>HF-20</b> (19032)	19" W x 7.1" H x 11.6" L	20-Slot Rack Mount Chassis	<b>AC150W</b> (19320-03)

\*<sup>1</sup> Note: US Model - PSAC08; European Model - PSAC09

\*<sup>2</sup> Note: One Power Adapter per Modem is required.

**TABLE 1. ENCLOSURE / CHASSIS**



**ENCLOSURE / CHASSIS SAMPLE PHOTOS**

## 1.3 SPECIFICATIONS

### General Specifications :

<b>Dimensions</b>	7 x 0.9 x 11.8in / 17.8 x 2.3 x 30cm (WxHxL)
<b>Weight</b>	0.28 kg (10 oz)
<b>Operating Temperature</b>	0° to 50°C (32° to 100°F)
<b>Humidity</b>	Up to 95% relative humidity (noncondensing)
<b>Altitude</b>	Up to 10,000 ft

### Electrical Interface:

<b>Power Requirements</b>	12VDC, 1Amp
<b>Connector</b>	DB25 Female
<b>Data Signal</b>	EIA RS-530 / MIL-STD-188-114 asynchronous, synchronous or isochronous
<b>Terminal Timing Data Rate</b>	20 Bps to 300 Kbps
<b>Source Timing Data Rate</b>	20 Bps to 150 Kbps
<b>DCE/DTE Options</b>	Switch Selectable

### Fiber Optic Interface:

<b>Models</b>	F2822A	F2824A	F2825A
<b>Wavelength</b>	Multimode 850nm	Multimode 1300nm	Single Mode 1300nm
<b>Connector</b>	ST	ST	ST
<b>Link Budget</b>	20 ± 1 dB	18 ± 1 dB	14 ± 1 dB
<b>Maximum Range</b>	2 Km	8 Km	14 Km
<b>Fiber Optic Cable *</b>	50/125, 62.5/125, 100/140	50/125, 62.5/125, 100/140	8/125, 9/125, 10/125

\*Note: Multimode tests were performed on 62.5/125 μM fiber optic cable.  
Single Mode tests were performed on 9/125 μM fiber optic cable.

### Major Features:

<ul style="list-style-type: none"><li>• Data rate up to 300 Kbps</li><li>• DCE/DTE Switch Selectable</li><li>• Terminal Timing/Source Timing Option</li><li>• 850nm Multimode, 1300nm Multimode and 1300nm Single Mode Options</li><li>• Eight Channel Data Multiplexer (Four in each direction)</li></ul>
--

## SECTION 2 INSTALLATION

### 2.1 GENERAL

This section contains information on the installation and initial checkout of the F282xA FOM II Series RS-530 Modems. Paragraph 2.2 contains general information on site selection and rack mounting. Paragraphs 2.3 and 2.4 provide instructions for connecting Model F282xA Modems to your system and selecting the different options. Paragraph 2.5 contains initial checkout procedures.

### 2.2 SITE SELECTION AND MOUNTING

The F282xA is designed to connect to the serial port (DB25 Male) of the terminal equipment with a cable (customer supplied). The F282xA is designed to be mounted in a single-card or dual-card standalone enclosure or may be rack mounted in a 2-slot or 20-slot chassis. (See Table 1 for Enclosure and Chassis dimensions).

### 2.3 POWER REQUIREMENTS

The F282xA is designed to operate from an AC power adapter or a DC power source with a DC voltage of +12 VDC. Before inserting the power adapter into an AC power source, the plug should be connected to the modem. No special tools are required. DC power may be used instead of the power adapter if available. This requires a 2.5 mm socket with the positive voltage on the center and the common on the concentric using +12 VDC at 1A.

### 2.4 SWITCH SETTINGS

There are a number of switches on the Model F282xA Modem used to select between DTE/DCE operation and Terminal/Source timing selection. Figure 5 shows the physical location of all of the switches, labeled SW1 through SW12. With the exception of the loopback switch (SW1), which is on the front panel of the modem card, **all of the switches should be set to the desired position prior to applying power to the modem**, and then left in those positions unless the overall link characteristics change.

Switch 3 (SW3), located between the optics and the XILINX CPLD Complex programmable Logic Device chip U3, contains 8 ON-OFF switch positions. The first two positions determine the interface standard that is expected as an input. For SW3, Position 2 is set to ON for DCE operation, and OFF for DTE operation. Position 1 is set to OFF for DCE operation, and ON for DTE operation.

The settings for SW12 should only be used on the modem which is configured for DTE configuration. This switch is used to set the Terminal or Source timing operation for a DTE modem. Both positions on this switch be OFF for Terminal timing, and ON for Source timing. SW12 should always be set to OFF position for a modem which is configured for DCE settings. These settings are listed in Table 2.

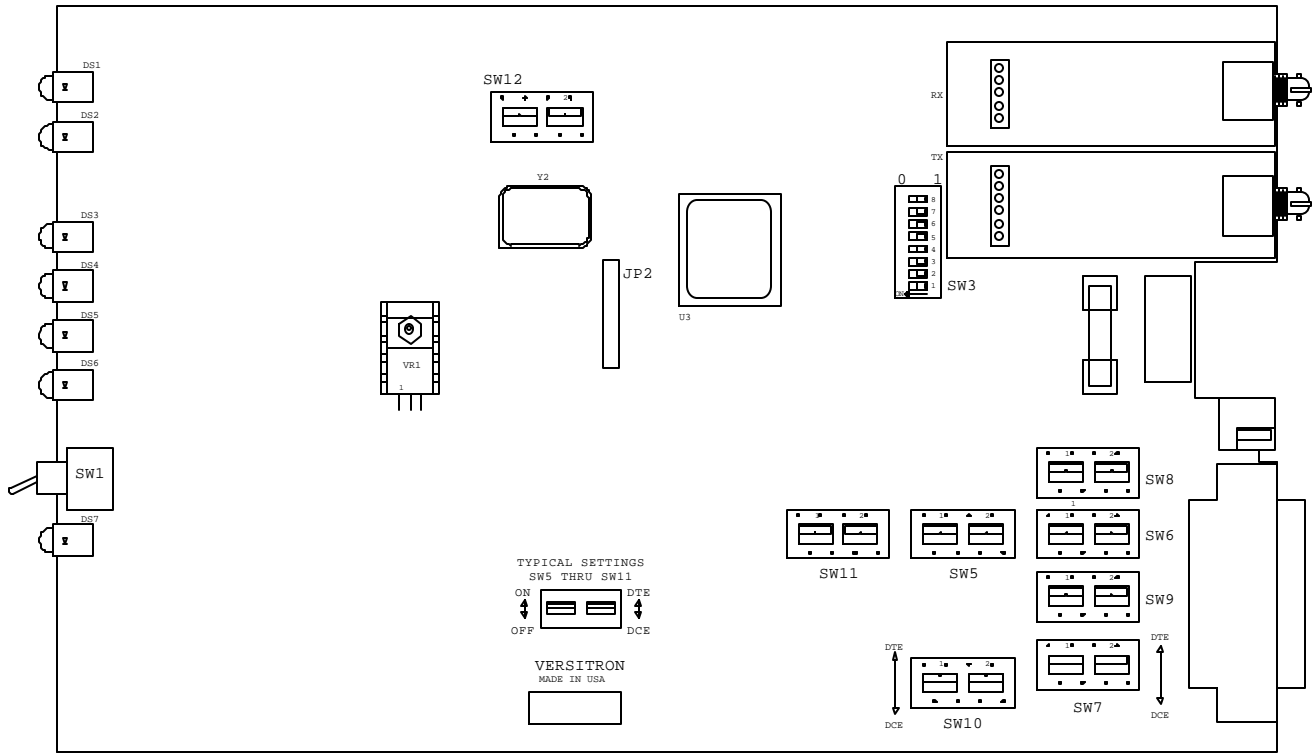

**FIGURE 5. SWITCH SETTINGS**

SW12 POSITION SETTINGS				
Position	DCE Terminal Timing	DCE Source Timing	DTE Terminal Timing	DTE Source Timing
1	OFF	OFF	OFF	ON
2	OFF	OFF	OFF	ON

**TABLE 2. TERMINAL/SOURCE TIMING SWITCH SETTINGS**

SWITCH	POSITION	ON	OFF	Description
1	Front Panel	X		Loopback enabled
1	Front Panel		X	Loopback function disabled
2	---	---	---	Does not exist on this modem
3	1	X		Circuits set for RS-530 DTE configuration
3	1		X	Circuits set for RS-530 DCE configuration
3	2	X		Interface set for RS-530 DCE
3	2		X	Interface set for RS-530 DTE
3	3		X	Set to OFF (Do not change)
3	4 - 8		X	Set to OFF (Do not change)
4	---	---	---	Does not exist on this modem
5,6,7,8,9,10,11	1 - 2	X		Interface set for DTE
5,6,7,8,9,10,11	1 - 2		X	Interface set for DCE
12	1 - 2	---	---	Refer to Table 2 for instructions

**TABLE 3. SWITCH SETTINGS**

## 2.5 TIMING MODE

The F282xA Modems can operate in two different timing modes: Source Timing and Terminal Timing. All timing modes are application specific and can be configured using Switch 12, Position 1 and 2 as listed in Table 2. As shown in Figure 5, Switch 12 (SW12) is located to the left of the CPLD U3 and above crystal Y2. The following sections describe the operation and associated required switch settings for each mode.

### 2.5.1 Source Timing

A realignment circuit is needed in the Source (external) Timing configuration to account for the inherent delays and jitter introduced by noise and asynchronous sampling at all frequencies. The realignment circuit is only used on the DTE units. A clock detection circuit checks for a clock signal on input pins 12 and 15 of the DB25 interface. If there are no clock signals on pins 12 and 15, no realignment takes place and data is output from the unit as it was received from the fiber optic input. If there are clock signals present, the realignment circuit processes the data signal recovered from the fiber optic receiver before it is output onto pins 2 and 14. In Source Timing mode, the F282xA Modem supports transmitted and received data, transmitted and received clocks, and eight control signals. The unit shall transmit and receive balanced signals at a data rate between 20Bps and 150 Kbps with a bit error rate of  $1 \times 10^{-9}$ . Refer to Table 2 for switch settings.

### 2.5.2 Terminal Timing

The Terminal (external) Timing mode is the basic mode of operation for the Model F282xA Modems. There is no circuit needed for data realignment. In Terminal Timing mode, the F282xA supports transmitted and received data, transmitted and received clocks, and eight control signals. Balanced signals, at a data rate from 20 Bps to 300 Kbps, are processed transparently by the Modem, with a bit error rate of  $1 \times 10^{-9}$ . Refer to Table 2 for switch settings.

## 2.6 LOOPBACK

The Model F282xA has one loopback feature. This feature allows the user to test the copper circuitry of the unit under test.

### 2.6.1 Fiber / Copper Loopback

The loopback feature of the Model F282xA allows the user to test the copper circuitry of the unit under test. This test feature is controlled by the front-panel switch (SW1). When SW1 is **ON**, the multiplexer bit goes high and the loopback test feature is enabled. The copper signal enters the board through the interface circuitry to the multiplexer circuit. The signals are multiplexed, demultiplexed and transmitted back to the test unit. This is true for all data, clock, and control signals. When SW1 is **OFF**, the multiplexer control bit goes low, and the unit functions normally. (The fiber optic circuitry may be tested by connecting a fiber optic patch cable between the transmit and receive optics of the modem under test.)

## 2.7 INITIAL CHECKOUT PROCEDURE

The Model F282xA FOM II Series products contain no power on/off switch. Once the unit is properly installed and power is applied it may be considered fully operational. The power indicator should remain on as long as power is supplied to the unit

Before beginning system operation the following items should be checked to verify proper installation:

1. Verify that the power plug is seated fully into the modem or the modem is seated firmly in the rack-mount enclosure.
2. Verify that the fiber optic cable is crossed transmit to receive from unit one to unit two.
3. Verify that the alarm LED goes out when the signal is applied to the optical receiver of the F282xA.
4. Verify the switch settings for the circuit configuration (i.e. Source/Terminal timing).

If a malfunction is detected during the initial checkout procedure, refer to Chapter 5 for information on isolating the malfunction in the unit.

## **SECTION 3 OPERATION**

### **3.1 INTRODUCTION**

This chapter contains a description of the operating controls and indicators associated with the Model F282xA FOM II Series modems. Since the Model F282xA is designed for continuous and uninterrupted operation, there are no operating requirements. Once the Model F282xA is powered up it should remain in service as long as required.

### **3.2 STATUS INDICATORS/AUDIBLE ALARM**

There are seven indicators on the F282xA: power (PWR), alarm (ALM), transmit data (TXD), receive data (RXD), transmit clock (TXC), receive clock (RXC), and Loopback (LOOP). No audible alarm is available.

### **3.3 OPERATING CONTROLS**

The only operating controls associated with the F282xA Modems are those used to select between DTE/DCE, Source/Terminal timing selection, and the loopback functions. These selections are normally made only at the time of installation. Further changes are not required unless the system requirements change.

## SECTION 4 THEORY OF OPERATION

### 4.1 INTRODUCTION

Basic operation of the Model F282xA is similar to a four-channel, full duplex multiplexer. The first channel is used for data. The next two channels are used for transmit and receive clock while the fourth multiplexer channel is used for aggregated control signals. This technique provides full transparency for the link, even when both clocks originate at the modem. The modem supplies both transmit and receive clocks to the Model F282xA, which are transmitted through the link and applied directly to the terminal.

The interface control signals are processed in a similar manner. The Request to Send signal from the terminal is transmitted through the link and applied to the modem. When the modem responds with Clear to Send, it will be transmitted through the link and applied to the terminal. With this technique, the terminal will see the RTS/CTS delay established by the modem.

If a fully transparent synchronous link is not required, the clock and control paths may be used as additional asynchronous data paths. The transmit and receive clock inputs will handle data rates from 20 Bps to 300 Kbps asynchronously; the control paths will handle data rates up to 9.6 Kbps.

## SECTION 5 MAINTENANCE AND TROUBLESHOOTING

### 5.1 INTRODUCTION

This chapter contains general information designed to isolate a malfunction in the Model F282xA to a replaceable unit. These units are not equipped with redundancy. Therefore, a failure in one of these units would interrupt service.

### 5.2 FAULT ISOLATION

The steps in Table 4 should be taken to check a non-operating modem.

STATUS INDICATOR	PROBABLE CAUSE	CORRECTIVE ACTION
POWER (PWR) LED is off.	No AC power.	Check that both ends of the Transformer are connected.
	Blown Fuse.	Replace with 250V 1A slo-blo fuse.
	Other power supply circuit problem.	Contact VERSITRON Customer Service for assistance.
LOSS of OPTICAL POWER (PWR) LED is on.	Incorrect optical signal level received at receiver input.	<ol style="list-style-type: none"> <li>1. Check that fiber optic cable is properly connected to RX connector.</li> <li>2. Check that the remote unit power is on and the TX fiber optic connector is connected properly.</li> <li>3. Measure the optical levels on both ends (if possible) in order to check the optical link.</li> <li>4. Contact VERSITRON Customer Service for assistance.</li> </ol>
DATA and CLOCK (TXD, RXD, TXC, RXC) LEDs are off or not responding as expected.	Switches in wrong position.	Check that the switch is set for the correct electrical interface.
	No input on the electrical interface connector.	Check that the interface connector is connected securely.
DATA AND CLOCK signal inverted.	Switches in wrong position.	Check that the switch is set for the correct electrical interface.
DATA signal inverted.	Inverted input on the electrical interface connector.	Check that the interface connector is wired per interface standard RS-530.

**TABLE 4. NON-OPERATIONAL INDICATORS**