

M62XXT
Fiber Optic MicroModem
Technical Manual

February 1999
Revision D

Copyright February 1999

VERSITRON, Inc
83 Albe Drive / Suite C
Newark, DE 19702
www.versitron.com

PROPRIETARY DATA

All data in this manual is proprietary and may not be disclosed, used or duplicated, for procurement or manufacturing purposes, without prior written permission by **VERSITRON**.

WARRANTY

All VERSITRON products are warranted against defects in materials and workmanship for one year from date of delivery. We will repair or, at our option, replace parts which during normal usage prove to be defective during the warranty period provided that:

1. You call VERSITRON at (302) 894-0699 or (800) 537-2296 and obtain a (RMA) Return Authorization Number. Please reference your RMA number on the outside of the box in which the item is returned.
2. Shipping charges are pre-paid.

No other warranty is expressed or implied and we are not liable for consequential damages. For repairs outside of the warranty period, the same procedure must be followed.

TABLE OF CONTENTS

PARAGRAPH	TITLE	PAGE
SECTION 1: DESCRIPTION OF EQUIPMENT		
1.1	INTRODUCTION.....	1
1.2	DESCRIPTION OF EQUIPMENT.....	1
1.2.1	FUNCTIONAL CHARACTERISTICS.....	1
1.2.2	PHYSICAL CHARACTERISTICS.....	1
1.3	SPECIFICATIONS.....	3
SECTION 2: INSTALLATION		
2.1	GENERAL.....	4
2.2	SITE SELECTION AND MOUNTING.....	4
2.2.1	SIGNAL INTERFACE.....	4
2.2.2	USER SELECTED OPTIONS.....	4
2.3	POWER REQUIREMENTS.....	4
2.3.1	INSTALLATION WITH AC POWER.....	5
2.3.2	INSTALLATION WITH DC POWER.....	5
2.4	INITIAL CHECKOUT PROCEDURE.....	5
SECTION 3: OPERATION		
3.1	INTRODUCTION.....	6
3.2	STATUS INDICATORS/ALARM.....	6
3.3	OPERATING CONTROLS.....	6
SECTION 4: THEORY OF OPERATION		
4.1	INTRODUCTION.....	7
SECTION 5: MAINTENANCE AND TROUBLESHOOTING		
5.1	INTRODUCTION.....	8
5.2	FAULT ISOLATION.....	8

LIST OF ILLUSTRATIONS

FIGURE	TITLE	PAGE
1.	OVERALL VIEW, M62XXT MICROMODEM	2
2.	INTERFACE EXTENDER CONFIGURATION.....	2
3.	MODEM LINK CONFIGURATION.	2
4.	SWITCH SETTINGS.....	5

SECTION 1 DESCRIPTION OF EQUIPMENT

1.1 INTRODUCTION

This manual provides general and detailed information on the installation and operation of the Model M62XXT series MicroModems. Section 1 contains a general description of the equipment. Section 2 contains installation instructions. Section 3 contains operating instructions. Section 4 provides the theory of operation. Section 5 contains maintenance and troubleshooting information.

Model Number	Part Number	Description
M621XT	19881-07	RS-530 or MIL-STD-188-114 input, 0-76.8 Kbps, short-wave, multimode, 850nm optics, ST connectors, DCE, up to 2 Km operational distance, EMI/RFI suppressed.
M622XT	19881-05	RS-530 or MIL-STD 188-114 input, 0-76.8 Kbps, short-wave, multimode, 850nm optics, ST connectors, DTE, up to 2 Km operational distance, EMI/RFI suppressed.

1.2 DESCRIPTION OF EQUIPMENT

1.2.1 Functional Characteristics

The Model M62XXT series MicroModem products are fiber-optic links designed for use as an interface extender (see Figure 2) or as a modem link (see Figure 3). The M621XT units are used at the DCE end of a circuit and the M622XT units are used at the DTE end. The M62XXT MicroModems, with 850nm LED optics, use a pair of fiber-optic cables of up to 2 Km (6,560 ft.) in length. The link can operate at any data rate from 1 Bps to 76.8 Kbps and appears fully transparent in both directions. The M62XXT MicroModems fully support the interface control signals associated with the EIA RS-530 (RS-422/423), RS-449 or V.35 (with adapters), or MIL-STD-188-114 standards. This is accomplished by multiplexing the control signals along with the clock and data signals and transmitting the combined signal to the remote unit. At the remote end the combined signal is demultiplexed and applied to the interface.

1.2.2 Physical Characteristics

The Model M62XXT MicroModems measure 2.4" high x 1.0" wide x 4.5" deep and may be mounted directly onto terminal interface connectors of data transmission equipment. VERSITRON also offers a 19" standard rack-mount chassis (MRR-16) for mounting up to 16 MicroModems and utilizing a common power supply. The M62XXT MicroModems require DC power for operation, with a one-pin connector for electrical input. There is a female DB25 connector for the digital interface and two ST connectors for the fiber-optic interface. Power may also be applied on pin 9 of the DB25 interface.



FIGURE 1. OVERALL VIEW, M62XXT MICROMODEM

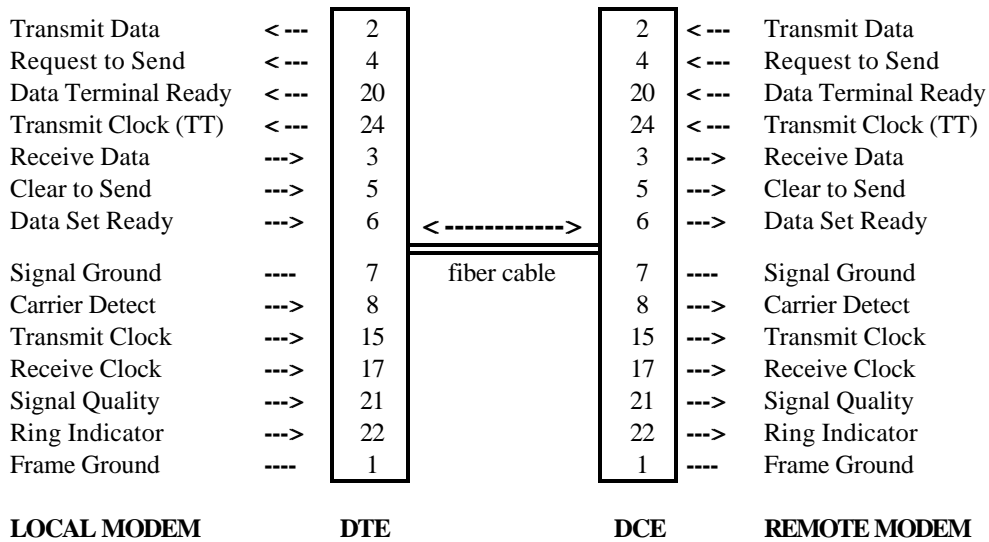

FIGURE 2. INTERFACE EXTENDER CONFIGURATION

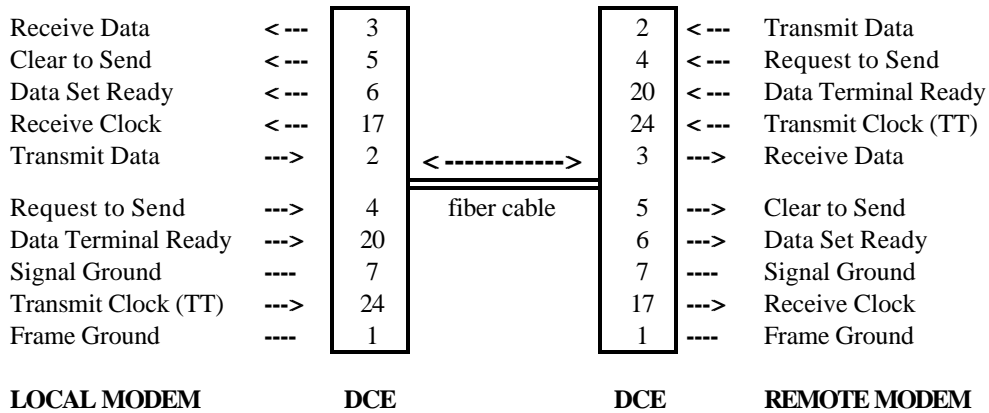

FIGURE 3. MODEM LINK CONFIGURATION

1.3 SPECIFICATIONS

Data Rate: Continuously variable from 1 Bps to 76.8 Kbps, synchronous (source time or terminal timed) / asynchronous / isochronous (Clock must be supplied externally).

Operating Mode/Range: Full duplex or simplex operation over a fiber-optic cable pair with maximum operating range of 2 Km (6,560 ft.).

Optical Interface: ST connectors, compatible with 50/125, 62.5/125 or 100/140 μM multimode fiber for 850nm operation.

Digital Interface: Signal levels and format conform to EIA RS-530 (RS-422/423), RS-449 or V.35 (with adapters), or MIL-STD-188-114. The M621XT has a female DB25 DCE connector for the electrical interface, to connect to a terminal. The M622XT has a male DB25 DTE connector for the electrical interface, to connect to a modem.

Bit Error Rate: Better than 10^{-9} .

Sampling Rate: 300 Khz (clock and data), 18.75 Khz (control lines). When asynchronous data is applied to control lines, there is approximately 5% jitter at a data rate of 1 Kbps.

Transmitter Power Output: -8 ± 2 dBm.

Receiver Sensitivity: -32 ± 2 dBm.

Link Margin: 20 dB with 100/140 μM fiber-optic cable, 15.5 dB with 62.5/125 μM cable, and 10.8 dB with 50/125 μM cable.

Dimensions: 2.4" H (6.1 cm) x 1.0" W (2.5 cm) x 4.5" D (11.4 cm).

Weight: 6.75 oz. (0.30 kg).

Power Requirements: 12 VDC / 1 A, (optional DC power adapter Model PSAC08 converts 110 VAC; Model PSAC09 converts 220 VAC). 5-15 VDC power may also be provided on pin 9 of the DB25 interface.

Environment: 0° to $+50^{\circ}\text{C}$ (32° to $+122^{\circ}\text{F}$) operating temperature; up to 95% relative humidity (non-condensing); up to 10,000 feet altitude; storage temperature -40° to $+70^{\circ}\text{C}$.

SECTION 2 INSTALLATION

2.1 GENERAL

This section contains information on installation and checkout of the M62XX series MicroModems. Paragraph 2.2 contains general information on site selection and rack mounting. Paragraph 2.3 contains instructions for connecting M62XX products to your system and selecting options. Paragraph 2.4 contains initial checkout procedures.

2.2 SITE SELECTION AND MOUNTING

The MicroModem M62XX products connect directly to the serial port (DB25 Connector) of the terminal equipment with two hand-tightened screws. When mounting to a PC, facsimile equipment or a STU III telephone, securely position the MicroModem allowing space for the power adaptor, if used. The MicroModems may also be mounted in a Model MRR-16 19-inch standard rack-mount chassis. In this configuration a 6" power jumper cable (Model M0001) is required for each MicroModem and a power transformer (Model M0004) provides power to the chassis. Two M0004 transformers may be used to provide power redundancy.

2.2.1 Signal Interface

Each M62XX MicroModem has a DB25 connector. The M621X has a terminal connection (female DB25) for DCE operation. The M622X has a modem connection (male DB25) for DTE operation.

2.2.2 User Selected Options

An internal switch is provided in order to select EIA or MIL operation. As shown in Figure 4, Switch 1 provides the option. Default settings for Switch 1 Positions 1, 2, 3, 4 and 6 are OFF; Positions 5, 7 and 8 are ON. With switch position 7 in the ON position, the MicroModem is set for EIA operation. With switch position 7 in the OFF position, MIL operation is set. By selecting EIA on one end of the link and MIL on the other, interface conversion occurs. The rest of the switches on the circuit board are for diagnostic purposes only and should not be moved by the user.

2.3 POWER REQUIREMENTS

The Model M62XXT micromodems operate from an AC power adapter or a DC power source with a DC voltage of +5 to +15 VDC. Using pin 9 of the DB25 connector, host power may be used. The power supplies used with the M62XXT MicroModems are the VERSITRON Model PSAC08 (US) and PSAC09 (VDE).

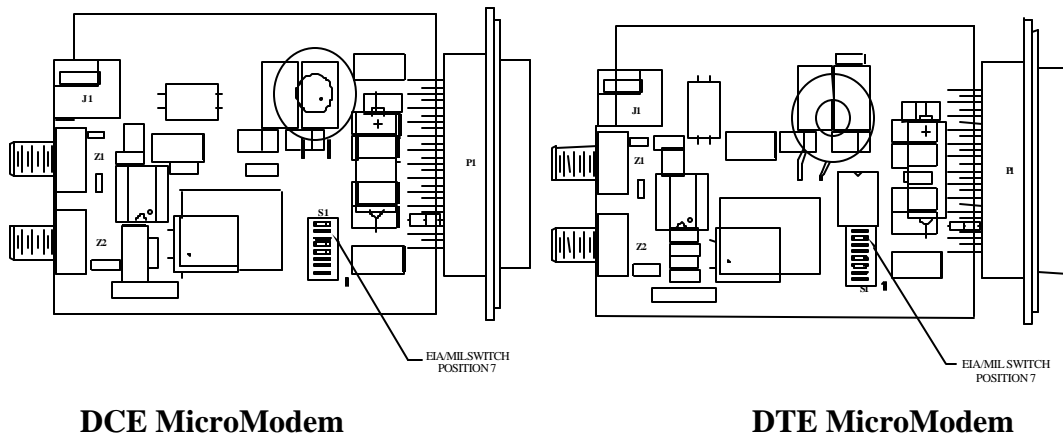

FIGURE 4. SWITCH SETTINGS

2.3.1 Installation with AC Power

Connect the power adapter to the M62XXT unit before inserting its plug into an AC power source. There are no special tools required.

2.3.2 Installation with DC Power

DC power may be used instead of an AC adapter, if available. This requires a 2.5 mm socket with the positive on the center and common on the concentric, and providing +12 VDC at 250 mA.

2.4 INITIAL CHECKOUT PROCEDURE

The Model M62XXT series products contain no power on/off switch. Once you install and apply power to the unit, it is fully operational.

Before beginning system operation the following items should be checked to verify proper installation:

1. Verify that the EIA/MIL switch is set to the correct position for your configuration: Switch is ON for EIA, OFF for MIL.
2. Verify that the fiber-optic cable is "crossed" i.e. connected properly from transmit to receive from one unit to the second.
3. Verify that the power plug is seated fully into the MicroModem or seated firmly in the rack mount enclosure.

If a malfunction is detected during the initial checkout procedure, refer to Chapter 5 for information on isolating the malfunction in the unit.

SECTION 3 OPERATION

3.1 INTRODUCTION

This chapter contains a description of the operating controls and indicators associated with Model M62XXT MicroModems. Since the Model M62XXT is designed for continuous and uninterrupted operation, there are no operating requirements. Once the Model M62XXT is powered up it should remain in service as long as required.

3.2 STATUS INDICATORS/AUDIBLE ALARM

There are no status indicators or audible alarms available with the Model M62XXT MicroModems. If these features are required for monitoring, a MicroModem may be connected to a Model F28XX FOM II series fiber-optic modem at one end of a circuit.

3.3 Operating Controls

The only operating control associated with the Model M62XXT is an internal switch used to select between either EIA RS-530 (RS-422/423) or MIL-STD-188-114. Factory setting is EIA RS-530. Further changes are not required unless the system requirements change.

SECTION 4 THEORY OF OPERATION

4.1 INTRODUCTION

Basic operation of the Model M62XXT is similar to a four-channel, full duplex multiplexer. The first channel is used for data. The next two channels are used for transmit and receive clock, while the fourth multiplexer channel is used for aggregated control signals. This technique provides full transparency for the link, even when both clocks originate at the modem. The modem supplies transmit and receive clocks which are transmitted through the link and applied directly to the terminal.

The interface control signals are processed in a similar manner. The Request to Send signal from the terminal is transmitted through the link and applied to the modem. When the modem responds with Clear to Send, it will be transmitted through the link and applied to the terminal. With this technique, the terminal will see the RTS/CTS delay established by the modem.

If a fully transparent synchronous link is not required, the clock and control paths may be used as additional asynchronous data paths. The transmit and receive clock inputs will handle data rates from 0 to 76.8 Kbps asynchronously; the control paths will handle data rates up to 1 Kbps with 5% distortion.

SECTION 5 MAINTENANCE AND TROUBLESHOOTING

5.1 INTRODUCTION

This chapter contains general information designed to isolate a malfunction in the Model M62XXT to a replaceable unit. These units are not equipped with redundancy. Therefore, a failure in one of these units would interrupt service.

5.2 FAULT ISOLATION

There are no status indicators on the M62XXT MicroModems. Therefore, you must remove the transmit fiber-optic cable to verify that the unit is emitting light (transmitting). If no light is present, check Pin 9 of the DB25 connector (if being used) or check the power adapter to insure that it is seated correctly and power is supplied to the unit. Swap out adapters to check for a bad power unit, if light is still not present.

If data is inverted on one end of the link, check the EIA/MIL switch for correct placement. The data will be inverted relative to the associated clock.