



*VersiVision*

FDVT1A0x / FDVR1A0x

1-CHANNEL DIGITALLY ENCODED VIDEO

AND

1-CHANNEL BI-DIRECTIONAL DATA

MULTIPLEXER

**USER'S MANUAL**

Revision C

© February 2006  
**VERSITRON, Inc.**  
83 Albe Drive / Suite C  
Newark, DE 19702  
[www.versitron.com](http://www.versitron.com)

## **PROPRIETARY DATA**

All data in this manual is proprietary and may not be disclosed, used or duplicated, for procurement or manufacturing purposes, without prior written permission by **VERSITRON**.

## **WARRANTY**

All VERSITRON products purchased after January 2001 carry a limited lifetime warranty against defects in materials and workmanship for the lifetime of the product. Purchases made prior to January 2001 are warranted for a period of one year from date of delivery. VERSITRON reserves the right to repair or, at our option, replace parts which during normal usage prove to be defective during the warranty period provided that:

1. You call VERSITRON at (302) 894-0699 or (800) 537-2296 and obtain a (RMA) Return Authorization Number. Please reference your RMA number on the outside of the box in which the item is returned.
2. Shipping charges are pre-paid.

No other warranty is expressed or implied and we are not liable for consequential damages. For repairs outside of the warranty period, the same procedure must be followed.

## Table of Contents

General Information .....	3
Introduction .....	3
Technical Specifications .....	3
Installation Instructions .....	6
Installation Procedure .....	6
Indicator LEDs .....	7
System Terminal Block Connections .....	8
Wiring Diagrams .....	10
Troubleshooting .....	12

***NOTE:** VERSITRON uses the same front panel for multiple products. Not all features are available on all models; therefore you should verify the features of your specific model.*

# GENERAL INFORMATION

## Introduction:

The VERSITRON *VersiVision* FDVT1A0x and FDVR1A0x Series video and data transmitter and receiver support simultaneous transmission of one channel of 8-bit digitally encoded video and one channel of bi-directional data over one multi-mode or single-mode optical fiber. The modules are universally compatible with major camera systems and support RS-485 and RS-232 data protocols. Plug and Play design ensures ease of installation and electronic and optical adjustments are never required.

## Model Number

Unit Type	Model Number
One-Channel Digitally Encoded Video/One-Channel Bi-Directional Data Transmitter	FDVT1A0x
One-Channel Digitally Encoded Video/One-Channel Bi-Directional Data Receiver	FDVR1A0x

## Technical Specifications:

### **VIDEO**

Video Input:	1 volt pk-pk (75 ohms)
Input/Output Channels:	1
Bandwidth:	5 Hz - 8 MHz
Bit Resolution:	8-bit
Differential Gain:	< 2%
Differential Phase:	< 0.6°
Tilt:	< 1%
S/N Ratio:	67dB (Weighed)

### **DATA**

Data Interface:	RS-485/RS-232
Data Channel:	1
Data Rate:	100Kbps
Bit Error Rate:	10 <sup>-9</sup>

<b>WAVELENGTH:</b>	850/1310nm Multimode 1310/1550nm Singlemode
--------------------	--

<b>OPTICAL EMITTER:</b>	Laser Diode
-------------------------	-------------

<b>NUMBER OF FIBERS:</b>	1
--------------------------	---

## Technical Specifications (cont.):

### **CONNECTORS**

Optical:	SC, ST (FC Optional)
Video:	BNC
Data:	Shield RJ-45 Plug

### **GENERAL**

Power Supply:	5VDC @ 300mA
Size:	4.57 x 5.31 x 1.42 Inches
Construction:	Aluminum
MTBF:	> 100,000 hours
Operating Temp:	-30° C to + 50° C
Storage Temp:	-40° C to + 85° C
Relative Humidity:	0% to 95% (non-condensing)

### **INDICATOR**

Blue:	Video Sync Present
Blue:	Data Sync Present
Orange:	Power On

## OPTICAL POWER BUDGET

Optical transmission distance is limited to optical loss of the fiber and any additional loss caused by connectors, splices, and patch panels.

### CAUTION!

The transmitter unit contains a laser-emitting diode located in the optical connector. This device emits invisible infrared electromagnetic radiation that can be harmful to human eyes. The radiation from this optical connector, if viewed closely without any protection, may cause instantaneous damage to the retina of the eye. Direct viewing of this LED should be avoided at all times.

Fiber	Wavelength	Transmitter		Receiver		Optical Power Budget	Max Distance
		Model	Output	Model	Sensitivity		
Singlemode	1310nm	FDVT 1A0x	-5 dBm	FDVR 1A0x	-26 dBm	21 dB	30 Km
Fiber	Wavelength	Receiver		Transmitter		Optical Power Budget	Max Distance
Model	Output	Model	Sensitivity				
Multimode	850/1310nm	FDVR 1A0x	-10 dBm	FDVT 1A0x	-22 dBm	12 dB	3 Km

# INSTALLATION INSTRUCTIONS

## Installation Procedure

The VERSITRON *VersiVision* FDVT1A0x and FDVR1A0x video transmission systems series are preset for immediate use. There are indicator LEDs on the units for monitoring the real-time status of video, data and power. The following instructions describe the typical installation procedure and the function of the LED indicators located on each unit.

1. Connect the video source (camera) to the video input BNC connector on the transmitter unit (FDVT1A0x) using coaxial cable.
2. Connect the video output BNC connector on the receiver unit (FDVR1A0x) to the video monitor using coaxial cable.
3. Connect the fiber optic cable between the transmitter and receiver units.
4. Apply the power supply to both the transmitter and receiver units.
5. When the power is applied, the orange POWER LED will light, indicating the presence of operating power. The blue VIDEO LED and the blue DATA LED will give an indication as stated on the following pages.
6. The system should now be operational.

## Indicator LEDs

The stand-alone units have integral LEDs that are used to monitor the state of the unit. There are one video LED, one power LED and four data LEDs on each unit. The LED labeled DATA1 is the only functional LED on this model. DATA2, DATA3, and, DATA4 are unavailable and normally OFF. The indicator LEDs function as follows:

### **TRANSMITTER and RECEIVER:**

**Power: ON:** (Orange) Indicates that correct power has been applied

#### **Transmitter:**

**VIDEO: OFF:** Indicates no video detected on input BNC connector  
(No Video present on input BNC)  
**ON:** (Blue) Indicates video detected on input BNC connector  
(Video present on input BNC)

**DATA1: OFF:** Indicates no data detected on the transmit data cable  
**Blinking:** (Blue) Indicates data transmitted at the rate of the operation data.

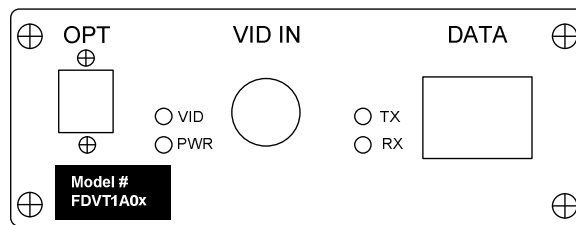

**\*Front Panel of FDVT1A0x (Transmitter)**

#### **Receiver:**

**VIDEO: OFF:** Indicates no video present on output BNC connector  
(No Video present on output BNC)  
**ON:** (Blue) Indicates video detected on output BNC connector  
(Video present on input BNC)

**DATA1: OFF:** Indicates no data detected on the receive data cable  
**Blinking:** (Blue) Indicates data received at the rate of the operation data.

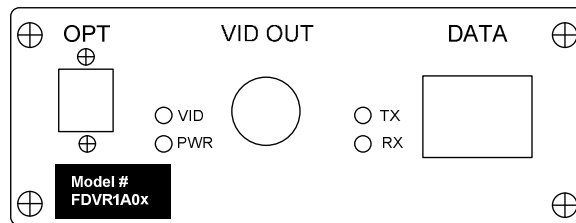

**\*Front Panel of FDVR1A0x (Receiver)**

## System Terminal Block Connections

The various input and output connections for the VERSITRON *VersiVision* FDVT1A0x and FDVR1A0x video transmission systems series are as follows:

### Video Input or Output: BNC Connectors

#### Data RS-485 Connection:

##### (Channel 1)

Terminal No.1 - ①: RS-485 (+)

Terminal No.2 - ②: RS-485 (-)

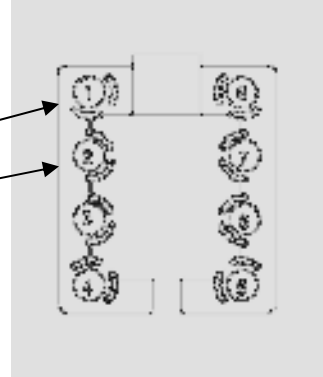

\*Terminal Block for Data Connection

#### Camera Site

Connect Terminal No.1 - ① in the terminal block to RS-485 (+) of the controlled unit (pan/tilt, dome), and connect Terminal No.2 - ② in the terminal block to RS-485 (-) of the controlled unit (pan/tilt, dome).

#### Control Site

Similarly, connect Terminal No.1 - ① in the terminal block to RS-485 (+) of the controlling unit (Keyboard Controller, Matrix, DVR), and connect Terminal No.2 - ② in the terminal block to RS-485 (-) of the controlling unit (Keyboard Controller, Matrix, DVR).

## System Terminal Block Connections (cont.)

### Data RS-232 Connection:

Terminal No.8 - ⑧: Ground

Terminal No.7 - ⑦: Signal being received in from fiber

Terminal No.6 - ⑥: Signal being transmitted out over fiber

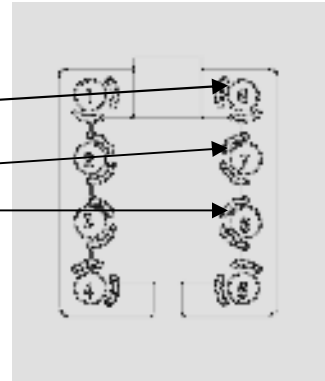

**\*Terminal Block for Data Connection**

### Camera Site

Connect Terminal No.7 - ⑦ (232T) in the terminal block to the RS-232 (232R) port of the controlled unit (pan/tilt, dome), and Terminal No.8 - ⑧ (GND) to ground.

### Control Site

Connect Terminal No.6 - ⑥ (232R) in the terminal block to the RS-232 Port (232T) of the controlling unit (Keyboard Controller, Matrix, DVR), and Terminal No.8 - ⑧ (GND) to ground.

# Wiring Diagrams

Typical wiring of RS-485 data control lines for PTZ cameras.

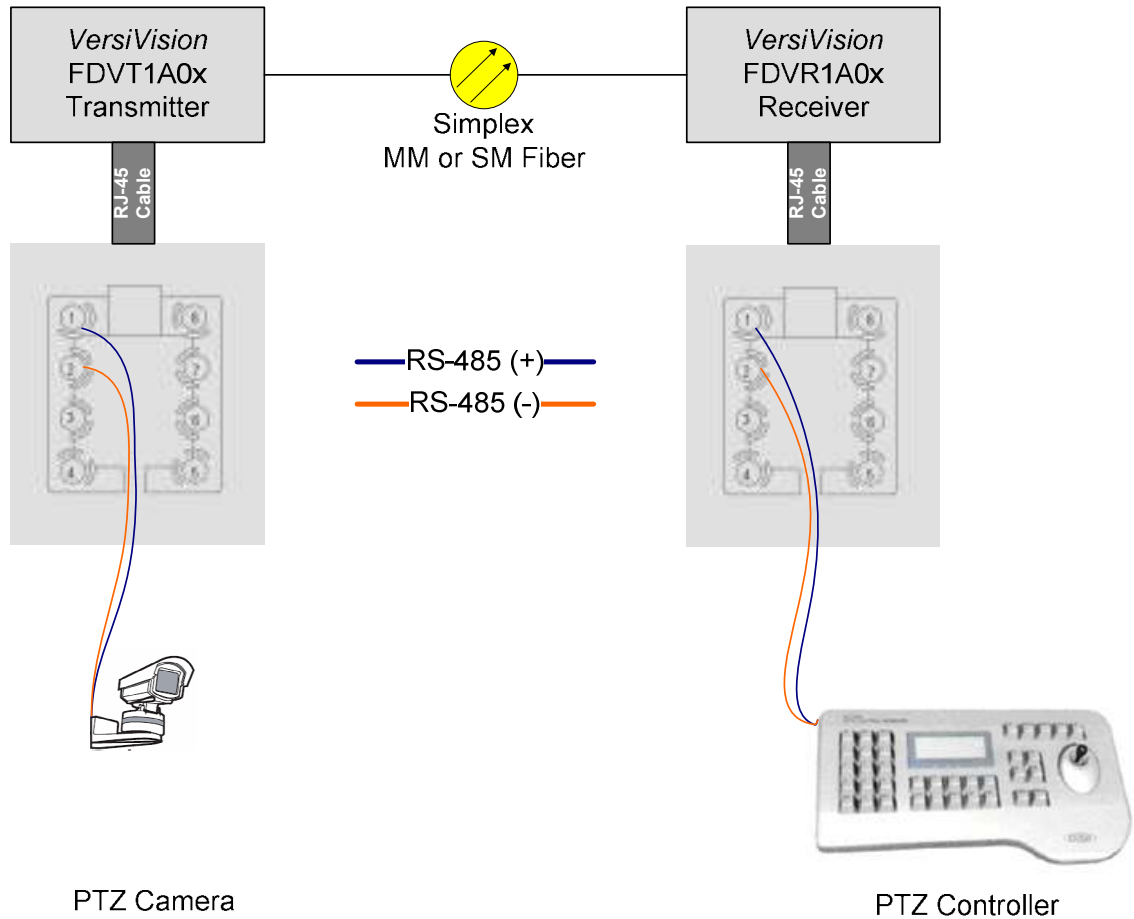

**NOTE:** If your PTZ Controller has an RJ-45 jack for data input you can use the RJ-45 cable to connect the PTZ Controller directly to the FDVR1A0x, bypassing the terminal block.

## Wiring Diagrams (cont.)

Typical wiring of RS-232 data control lines for PTZ cameras.

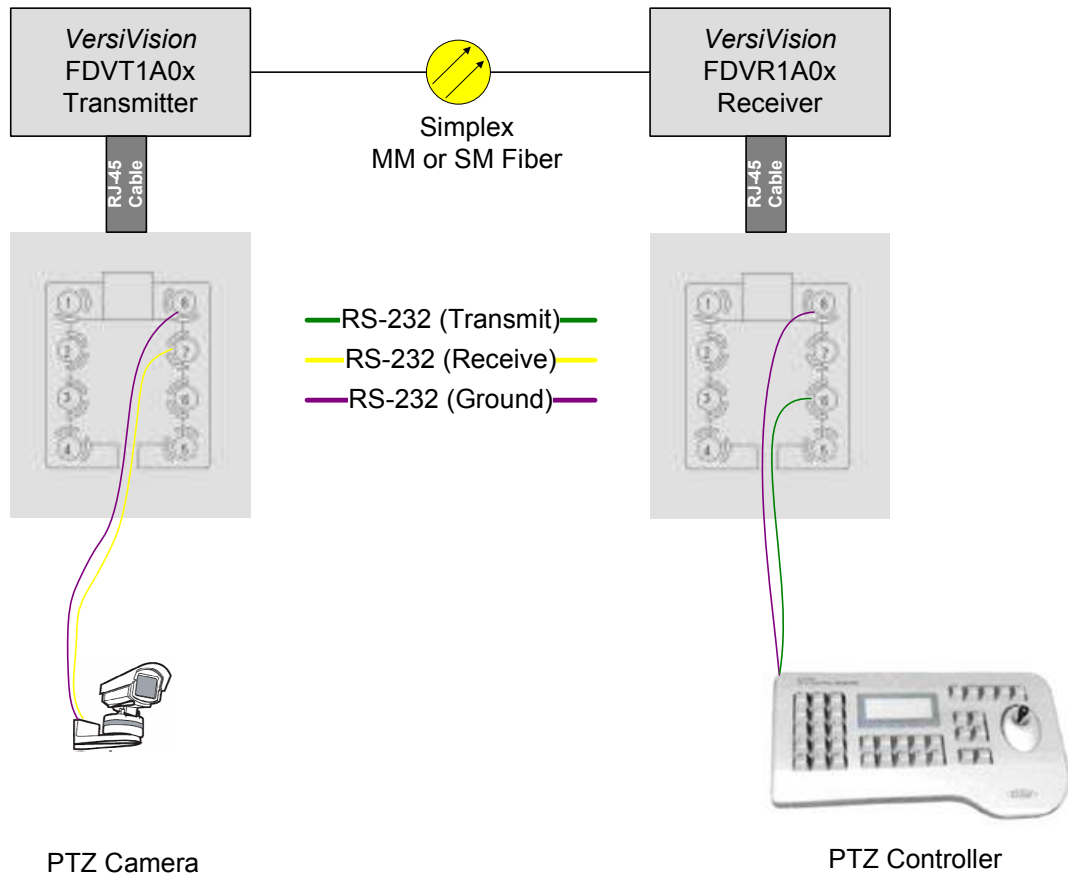

**NOTE:** If your PTZ Controller has an RJ-45 jack for data input you can use the RJ-45 cable to connect the PTZ Controller directly to the FDVR1A0x, bypassing the terminal block.

# TROUBLESHOOTING

## Optical Fiber

The VERSITRON *VersiVision* FDVT1A0x and FDVR1A0x video transmission systems series is available for most applications using multi-mode or single-mode optical fibers. Please be certain that the correct size and type of the fiber is being used for the particular transmitter/receiver combination.

Also be certain that the attenuation and bandwidth of the fiber optic cable being used is within the range of the system's loss budget specifications.

## General

Any dirt or dust may easily pollute or block the fiber from accepting or radiating light. Therefore, please try to keep the optical connector clear and always use the dust caps whenever the connector is exposed to air. It is suggested that the tip of the optical connector should be carefully cleaned with a lint-free cloth moistened with alcohol from time to time.

The status of any of the VIDEO LED should provide the first clue as to the origin of any operational failure. If the VIDEO LED on the receiver unit is off, it usually means that the fiber is broken or has too much attenuation.

Please also make sure that the transmitter and the receiver are not used in opposite positions.

If the system is still not working after examining the above possibilities, please contact our Customer Service Department for further assistance

## Data Link

Even when installed exactly as directed, it is possible that the data/audio function may fail to operate properly. If this problem occurs, first please check the data cable, and then check whether the data cable connector is firmly inserted into the RJ-45 port.

If the system is still not working after examining the above possibilities, please contact our Customer Service Department for further assistance