



VersiVision

FDVT101x / FDVR101x

1-CHANNEL DIGITALLY ENCODED VIDEO

AND

1-CHANNEL FORWARD AUDIO

MULTIPLEXER

USER'S MANUAL

Revision B

© February 2006
VERSITRON, Inc.
83 Albe Drive / Suite C
Newark, DE 19702
www.versitron.com

PROPRIETARY DATA

All data in this manual is proprietary and may not be disclosed, used or duplicated, for procurement or manufacturing purposes, without prior written permission by **VERSITRON**.

WARRANTY

All VERSITRON products purchased after January 2001 carry a limited lifetime warranty against defects in materials and workmanship for the lifetime of the product. Purchases made prior to January 2001 are warranted for a period of one year from date of delivery. VERSITRON reserves the right to repair or, at our option, replace parts which during normal usage prove to be defective during the warranty period provided that:

1. You call VERSITRON at (302) 894-0699 or (800) 537-2296 and obtain a (RMA) Return Authorization Number. Please reference your RMA number on the outside of the box in which the item is returned.
2. Shipping charges are pre-paid.

No other warranty is expressed or implied and we are not liable for consequential damages. For repairs outside of the warranty period, the same procedure must be followed.

Table of Contents

General Information	3
Introduction	3
Technical Specifications	3
Installation Instructions	6
Installation Procedure	6
Indicator LEDs	7
System Terminal Block Connections	8
Wiring Diagrams	9
Troubleshooting	10

***NOTE:** VERSITRON uses the same front panel for multiple products. Not all features are available on all models; therefore you should verify the features of your specific model.*

GENERAL INFORMATION

Introduction:

The VERSITRON *VersiVision* FDVT101x and FDVR101x Series video/audio transmitter and receiver support simultaneous transmission of one channel of 8-bit digitally encoded video and one channel of forward audio over one multi-mode or single-mode optical fiber. The modules are universally compatible with major camera systems and Plug and Play design ensures ease of installation and electronic and optical adjustments are never required.

Model Number

Unit Type	Model Number
One-Channel Digitally Encoded Video/One-Channel Forward Audio Transmitter	FDVT101x
One-Channel Digitally Encoded Video/One-Channel Forward Audio Receiver	FDVR101x

Technical Specifications:

VIDEO

Video Input	1 volt pk-pk (75 ohms)
Input/Output Channels	1
Bandwidth	5 Hz - 8 MHz
Bit Resolution	8-bit
Differential Gain	< 2%
Differential Phase	< 0.6°
Tilt	< 1%
S/N Ratio	67dB (Weighed)

AUDIO

Audio Impedance	600 Ω
Input/Output Level	0dBm (typical)
Frequency Response	10 Hz - 20 KHz
Bit Resolution	24-Bit
S/N Ratio	88dB

WAVELENGTH	850/1310nm Multimode 1310/1550nm Singlemode
-------------------	------------------------------------------------

OPTICAL EMITTER:	Laser Diode
-------------------------	-------------

NUMBER OF FIBERS	1
-------------------------	---

Technical Specifications (Cont):

CONNECTORS

Optical	SC, ST (FC Optional)
Video	BNC
Audio	Shield RJ-45 Plug

GENERAL

Power Supply	DC12V @ 500mA
Size	7.68 x 7.52 x 1.42 Inches
Construction	Aluminum
MTBF	> 100,000 hours
Operating Temp	-30° C to + 50° C
Storage Temp	-40° C to + 85° C
Relative Humidity	0% to 95% (non-condensing)

INDICATOR

Blue	Video Sync Present
Orange	Power On

OPTICAL POWER BUDGET

Optical transmission distance is limited to optical loss of the fiber and any additional loss caused by connectors, splices, and patch panels.

CAUTION!

The transmitter unit contains a laser-emitting diode located in the optical connector. This device emits invisible infrared electromagnetic radiation that can be harmful to human eyes. The radiation from this optical connector, if viewed closely without any protection, may cause instantaneous damage to the retina of the eye. Direct viewing of this LED should be avoided at all times.

Fiber	Wavelength	Transmitter		Receiver		Optical Power Budget	Max Distance
		Model	Output	Model	Sensitivity		
Singlemode	1310nm	FDVT 101x	-5 dBm	FDVR 101x	-26 dBm	21 dB	30km
Fiber	Wavelength	Receiver		Transmitter		Optical Power Budget	Max Distance
Model	Output	Model	Sensitivity				
Multimode	1310nm	FDVR 101x	-10 dBm	FDVT 101x	-22 dBm	12 dB	3km

INSTALLATION INSTRUCTIONS

Installation Procedure

The VERSITRON *VersiVision* FDVT101x and FDVR101x video transmission systems series are preset for immediate use. There are indicator LEDs on the units for monitoring the real-time status of video and power. The following instructions describe the typical installation procedure and the function of the LED indicators located on each unit.

1. Connect the video source (camera) to the video input BNC connector on the transmitter unit (FDVT101x) using coaxial cable.
2. Connect the video output BNC connector on the receiver unit (FDVR101x) to the video monitor using coaxial cable.
3. Connect the fiber optic cable between the transmitter and receiver units.
4. Apply the power supply to both the transmitter and receiver units.
5. When the power is applied, the orange POWER LED will light, indicating the presence of operating power. The blue VIDEO LED will give an indication as stated on the following pages.
6. The system should now be operational.

Indicator LEDs

The stand-alone units have integral LEDs that are used to monitor the state of the unit. There are one video LED and one power LED. The indicator LEDs function as follows:

TRANSMITTER and RECEIVER:

Power: ON: (Orange) Indicates that correct power has been applied

Transmitter:

VIDEO: OFF: Indicates no video detected on input BNC connector
(No Video present on input BNC)

ON: (Blue) Indicates video detected on input BNC connector
(Video present on input BNC)

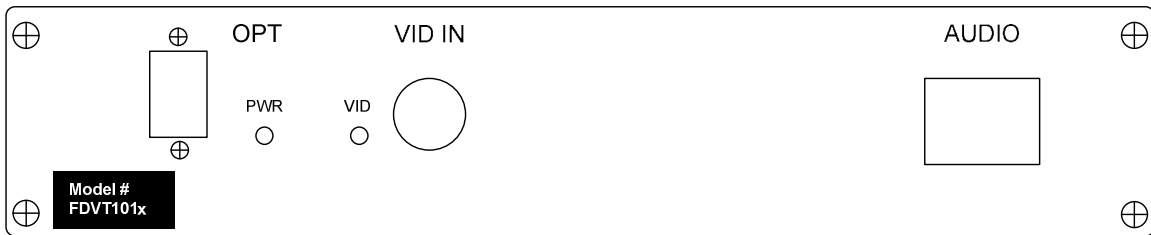

***Front Panel of FDVT101x (Transmitter)**

Receiver:

VIDEO: OFF: Indicates no video present on output BNC connector
(No Video present on output BNC)

ON: (Blue) Indicates video detected on output BNC connector
(Video present on input BNC)

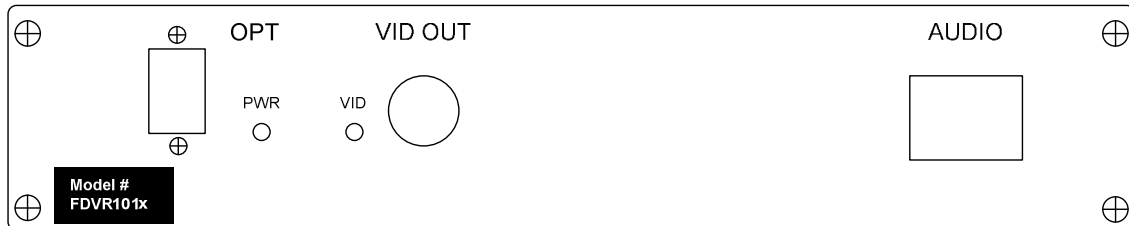

***Front Panel of FDVR101x (Receiver)**

System Terminal Block Connections

The various input and output connections for the VERSITRON *VersiVision* FDVT101x and FDVR101x video transmission systems series are as follows:

Video Input or Output: BNC Connectors

Audio Input/Output Connection:

Terminal No.6——⑥: Ground

Terminal No.5——⑤: Audio

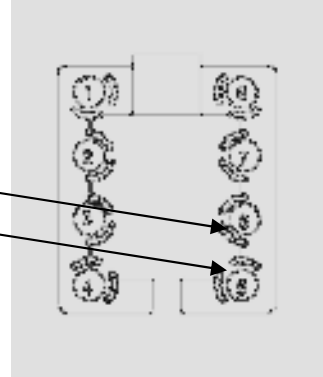

***Terminal Block for Audio Connection**

Camera Site

Connect the Terminal No.5——⑤ in the terminal block for audio connection to Channel 1 of the audio source, and Terminal No.6——⑥ in the terminal block to Ground.

Control Site

Connect the Terminal No.5——⑤ in the terminal block for audio connection to Channel 1 of the speaker, and Terminal No.6——⑥ in the terminal block to Ground.

Wiring Diagrams

Typical wiring of the audio channels.

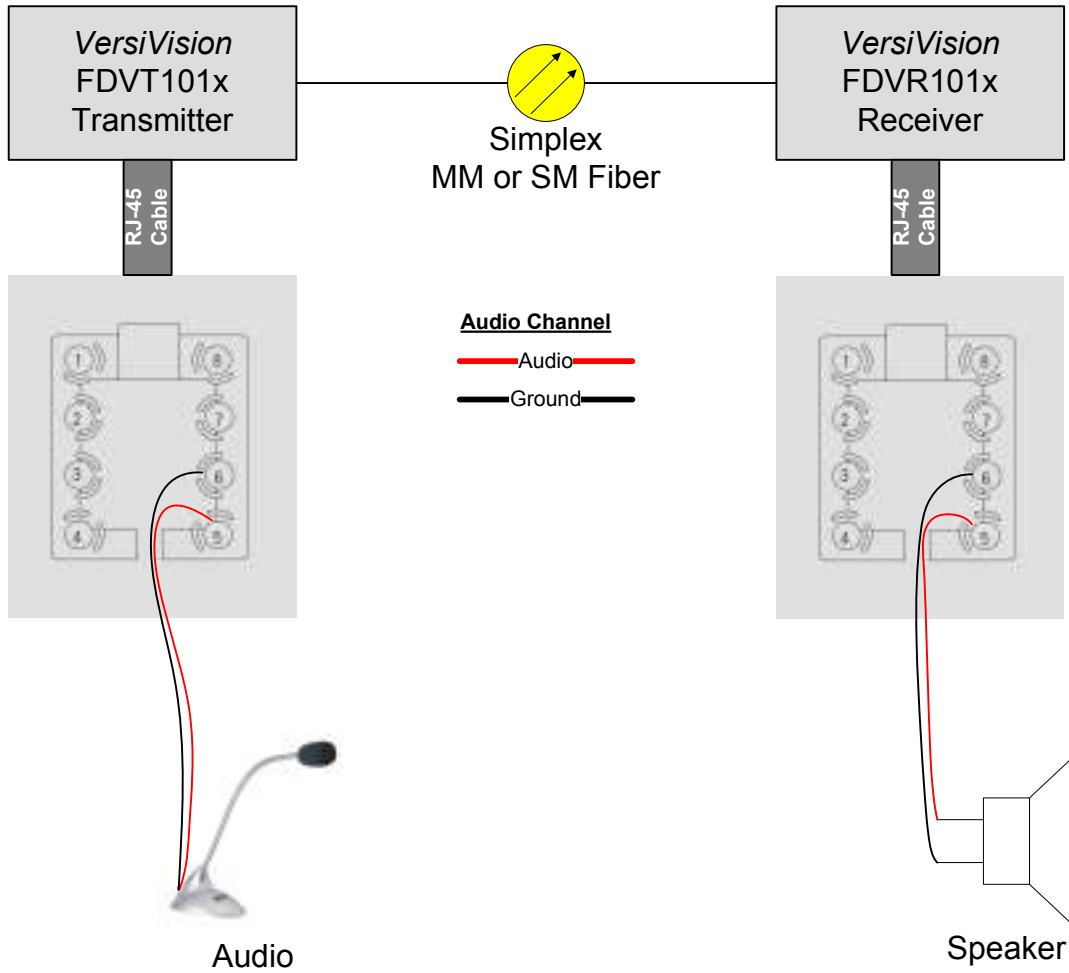

TROUBLESHOOTING

Optical Fiber

The VERSITRON *VersiVision* FDVT101x and FDVR101x video transmission systems series is available for most applications using multi-mode or single-mode optical fibers. Please be certain that the correct size and type of the fiber is being used for the particular transmitter/receiver combination.

Also be certain that the attenuation and bandwidth of the fiber optic cable being used is within the range of the system's loss budget specifications.

General

Any dirt or dust may easily pollute or block the fiber from accepting or radiating light. Therefore, please try to keep the optical connector clear and always use the dust caps whenever the connector is exposed to air. It is suggested that the tip of the optical connector should be carefully cleaned with a lint-free cloth moistened with alcohol from time to time.

The status of any of the VIDEO LED should provide the first clue as to the origin of any operational failure. If the VIDEO LED on the receiver unit is off, it usually means that the fiber is broken or has too much attenuation.

Please also make sure that the transmitter and the receiver are not used in opposite positions.

If the system is still not working after examining the above possibilities, please contact our Customer Service Department for further assistance

Audio Link

Even when installed exactly as directed, it is possible that the audio function may fail to operate properly. If this problem occurs, first please check the audio connections, and then check whether the data cable connector is firmly inserted into the RJ-45 ports.

If the system is still not working after examining the above possibilities, please contact our Customer Service Department for further assistance