

Versimux
Fiber Optic Multiplexer
Technical Manual

Released January, 2000
Revision C

Copyright January, 2000

VERSITRON, Inc.
83 Albe Drive / Suite C
Newark, DE 19702
www.versitron.com

A00015001

PROPRIETARY DATA

All data in this manual is proprietary and may not be disclosed, used or duplicated, for procurement or manufacturing purposes, without prior written permission by **VERSITRON**.

WARRANTY

All VERSITRON products are warranted against defects in materials and workmanship for one year from date of delivery. We will repair or, at our option, replace parts that during normal usage prove to be defective during the warranty period provided:

1. You call VERSITRON at (302) 894-0699 or (800) 537-2296 and obtain a Return Authorization Number. This number must be referenced on the box the item is shipped in.
2. Shipping charges are pre-paid.

No other warranty is expressed or implied and we are not liable for consequent damages. For repairs outside of the warranty period, the same procedure must be followed.

TABLE OF CONTENTS

Paragraph	Title	Page
Chapter 1. Description of Equipment		
1.1	Introduction	1
1.2	General Description	1
1.2.1	Functional Characteristics	1
1.2.2	Physical Characteristics	1
1.3	Specifications	3
Chapter 2. Installation		
2.1	General	5
2.2	Equipment Supplied	5
2.2.1	CAM-1 Circuit Card Assembly	5
2.2.2	Power Supply Modules	6
2.3	Installation Procedure	7
2.3.1	Chassis Installation	7
2.3.2	CAM-1 Card	7
2.3.3	Port Cards	7
2.3.4	Fiber Optic Interface	7
2.3.5	Operating Power	8
2.3.6	Interface Cabling	8
2.3.7	Remote Control/Status Panel Interface	8
Chapter 3. Operation		
3.1	Introduction	9
3.2	Power Supply Output Module	9
3.3	Power Supply Input Module	9
3.4	CAM-1 Card	10
Chapter 4. System Configurations		
4.1	General	11
4.2	Digital Port Configurations	11
4.3	Telephone Port Configurations	11
Chapter 5. Maintenance and Troubleshooting		
5.1	Routine Maintenance	12
5.1.1	Introduction	12
5.1.2	Inspection	12
5.2	Routine Service	12
5.2.1	Introduction	12
5.2.2	Test	12
5.3	Troubleshooting	13
5.3.1	Fault Finding	13
5.3.2	Built-In Test Capability	14
5.4	Module Fault Liability	15
5.4.1	Fault Finding	16
5.4.2	Fault Isolation	17

List of Tables

1-1	Currently Available Port Cards	4
2-1	Remote Control/Status Indicator	8

List of Illustrations

1-1	Simplified Block Diagram	2
1-2	Overall View, Versimux™ Chassis	2
1-3	Versimux™ Port Cards	4
2-1	CAM-1 Circuit Card Assembly	5
2-2	Power Supply Modules	6
4-1	Typical Digital Port Configurations	11
4-2	Typical Telephone Port Configurations	11
5-1	Signal Path, Local Unit in Test Mode	14
5-2	Signal Path, Local and Remote Unit in Test Mode	15

CHAPTER 1

DESCRIPTION OF EQUIPMENT

1.1 INTRODUCTION

This manual provides general and detailed information on the installation and operating procedures for the Versimux™, a versatile time division multiplexer. Chapter 1 of this manual contains general information. Chapter 2 contains installation instructions, with operating procedures located in Chapter 3. Chapter 4 contains a general description of typical system configurations. Chapter 5 contains instructions for maintenance and troubleshooting.

1.2 DESCRIPTION OF EQUIPMENT

The Versimux™ was designed on a modular basis to provide the maximum degree of flexibility in system configuration. The basic unit consists of a chassis equipped with a power supply and a master multiplexer card. Individual port cards plug into the chassis as required. Table 1-1 lists the different port cards used with the Versimux™.

1.2.1 FUNCTIONAL CHARACTERISTICS

Figure 1-1 is a simplified block diagram of the principal operating circuits used in the Versimux™. Individual port cards plug directly into the Versimux™ chassis. The port cards provide an interface point between the external equipment and the Channel Allocation Master (CAM-1) card. The CAM-1 card accepts the transmit data signals from all of the port cards, multiplexes the signals together, and transmits the combined signal to the remote unit over the fiber optic cable. At the remote unit, the combined signal is demultiplexed and applied to the appropriate port cards. Using time division multiplexing techniques, the Versimux™ multiplexer will combine data, clock, and control signals for up to 56 channels over one fiber optic cable pair. Data rates to 76.8 Kbps are possible. Both multimode and singlemode versions are available.

1.2.2 PHYSICAL CHARACTERISTICS

The Versimux™ multiplexer is configured to operate in the model OMC-14 chassis. Up to 14 individual plug-in port cards are used to interface each data or voice channel. The OMC-14 chassis is 8 3/4" high and designed for mounting in a standard 19 " wide rack. Port cards are installed from the front. All connections are made from the rear of the chassis. Figure 1-2 is an overall view of the OMC-14 (Optical Multiplexer Chassis-14).

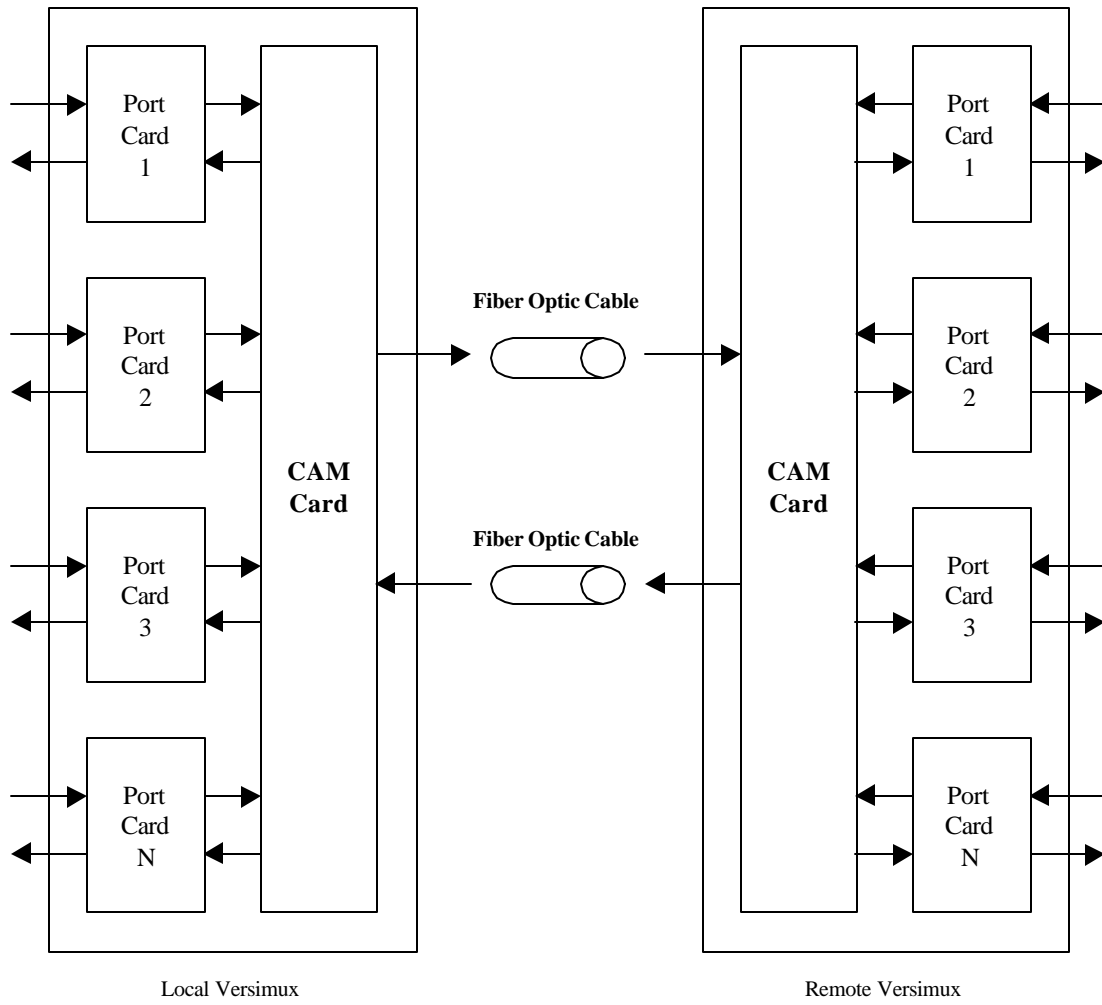

Figure 1-1. Simplified Block Diagram

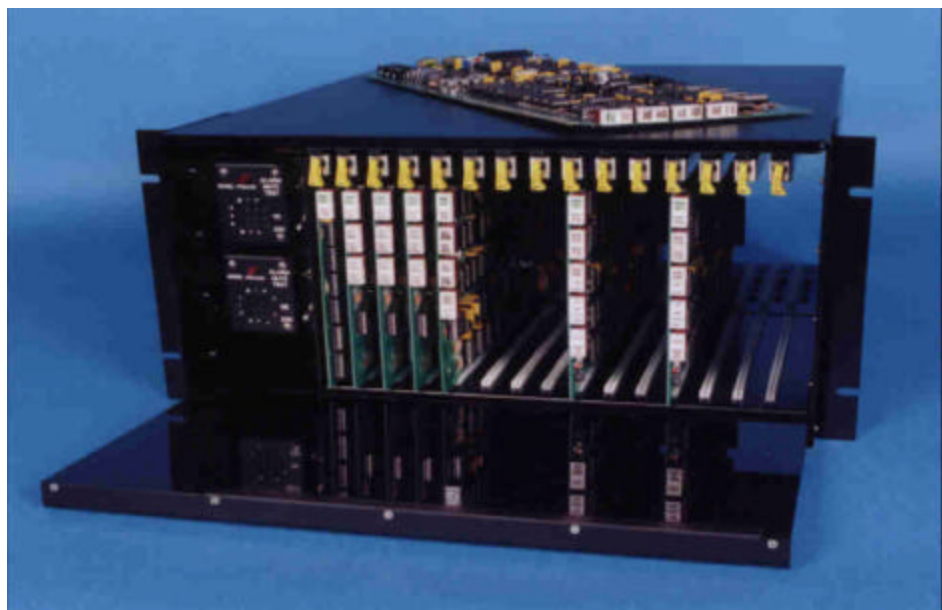
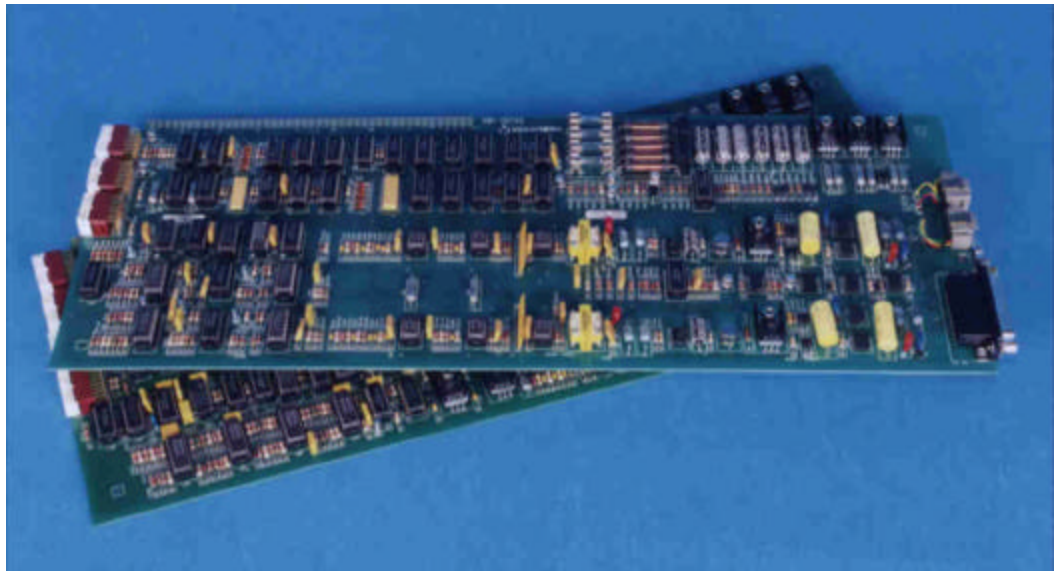

Figure 1-2. Overall View, Model OMC-14 Versimux Chassis



**Figure 1-3
Versimux Port Cards**

External Interface	For Use With	Data Rate/ Capacity	Direct Drop Digital Interface
<u>High Speed Data</u>			
RS-449/MIL	DCE/DTE	50,56,64,76.8 Kbps	MP908
V.35	DCE/DTE	50,56,64,76.8 Kbps	MP918
<u>Low Speed Data</u>			
RS-232/MIL	DCE/DTE	Up to 38.4 Kbps	MP907
RS-449/MIL	DCE/DTE	Up to 38.4 Kbps	MP917
RS-232/MIL	Dual DCE	Up to 38.4 Kbps	MP927
TTL,MIL,RS-422, RS-423,V.35	4 Duplex	4 Async to 38.4 Kbps	MP949
<u>Telephone/Analog</u>			
2-wire	Exchange Side	Dual Duplex	MP9701
2-wire	Subscriber Side	Dual Duplex	MP9711
4-wire	Voice Grade	Dual Duplex	MP9301

Table 1-1. Port Cards

1.3 SPECIFICATIONS

Number of Ports: The Versimux™ port card functions as the heart of the Versimux multiplexing system. Versimux™ starts with a basic building block enclosure (OMC-14 chassis) with slots for 15 cards, each powered by a dual redundant power supply. The master multiplexer (CAM-1) is housed in the first slot; the other 14 slots house up to 14 port cards. Port cards are plug-compatible with specific interfaces and support required control signals.

Operation Mode/Range: The Versimux™ is compatible with either multimode or single mode fiber. Multimode 50/125 μM, 62.5/125 μM, and 100/140 μM cable may be used. Single mode 9/125 μM or 10/125 μM may be used. The CAM-1 (Channel Allocation Master) card provides the optical interface connections linking the “local” Versimux chassis to the “remote” Versimux™ chassis. The Cam-1 cards are available in three versions:

CAM-1-2	850 nm multimode	2 km distance
CAM-1-4	1300 nm multimode	6 km distance
CAM-1-5	1300 nm single mode	15 km distance

All CAM-1 cards have ST optical connectors as standard.

Digital Interface: EIA-RS-232/MIL-188C, EIA-RS-449, V.35, and MIL-188-114. (Determined by the type of port card used.)

Data Rate: The maximum data rate is 76.8 Kbps. Some port cards offer data agility up to a specified data rate while other port cards have switch-selectable data rates.

Analog Interface: Telephone port cards are available which support two voice channels. Four control signals are multiplexed along with each voice channel. Either dial pulse or DTMF signaling may be used.

Dimensions: The OMC-14 chassis is 8 3/4” high by 17 1/2” deep and fits in a standard 19” wide rack. Port cards are 6 7/8” high by 17” deep.

Weight: The OMC-14 chassis with redundant power supplies and the CAM-1 card weigh 50 pounds. A typical port card weighs 1 ½ pounds.

Power Requirements: The Versimux™ is designed to operate with dual redundant power supplies. Power source is 115/230 VAC ± 10%, 50/60 Hz. Power supplies may require up to a 100-watt input depending on the loading.

Environmental: The Versimux™ is designed to operate over a temperature range of 0°C to +40° C; up to 95% relative humidity (non-condensing); up to 10,000 feet altitude. Storage Temperature is -40° C up to +70° C.

CHAPTER 2 INSTALLATION

2.1 GENERAL

This chapter contains detailed procedures for installing the Versimux™ chassis and CAM-1 card. Refer to the appropriate instruction manual for information on installing the individual port cards.

2.2 EQUIPMENT SUPPLIED

The basic Versimux™ configuration consists of the OMC-14 chassis, a Cam-1 card, and two sets of power supply modules. (Reference Figure (1-2). The items are further described in the following paragraphs.

2.2.1 CAM-1 CIRCUIT CARD ASSEMBLY

The CAM-1 (Channel Access Master) card is shown in Figure 2-1. This card performs the master multiplexing function, combining all of the outputs of the individual port cards into one aggregate signal. This card also contains the driver/receiver interface for conversion to fiber optics.

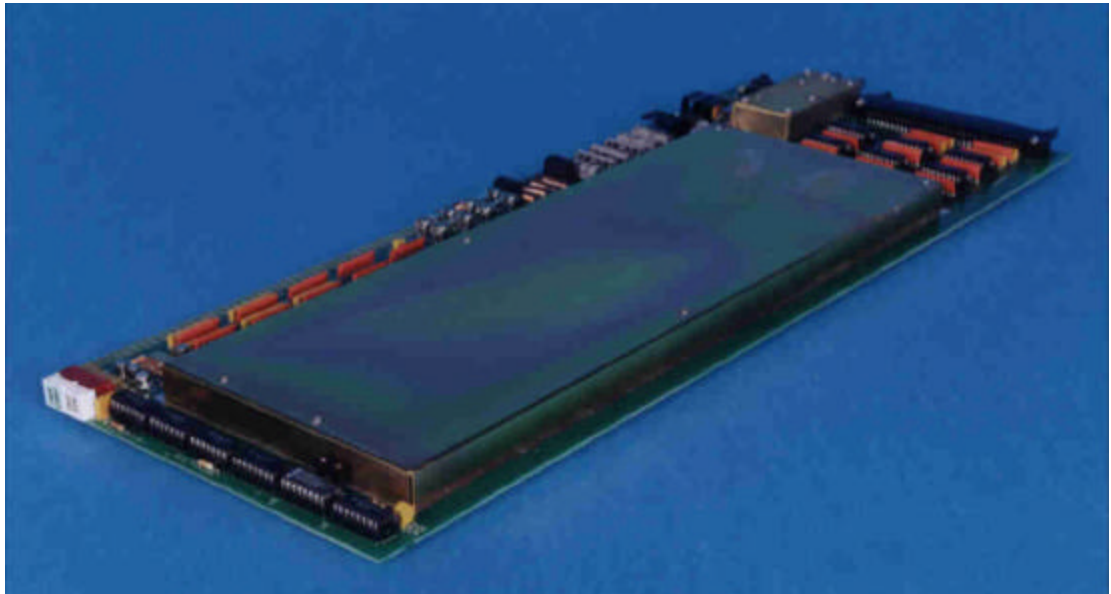

**Figure 2-1. CAM-1 (Channel Access Master)
Circuit Card Assembly**

2.2.2 POWER SUPPLY MODULES

The standard Versimux™ configuration contains dual power supplies to provide 100% redundancy. Each power supply (Model PSAC01) consists of an input module (Model PSAC02) and an output module (Model PSAC03). See Figure 2.2. The input module (Model PSAC02) provides an interface point for the AC power input and for a remote transformer, voltage selection switch, and the loss of power alarm circuitry.

Note: The Versimux™ requires two input and two output power supplies or the alarm circuit will continuously sound. A single power supply set (Model PSAC01) will carry the full load of the chassis if one of the power supplies fails.

Power supplies for the Versimux™ are generally ordered as Model PSAC01. The factory automatically ships an input module (Model PSAC02) and an output module (Model PSAC03) together as a Model PSAC01.



**Figure 2.2 Model PSAC01 Power Supply
Showing PSAC02 input module and PSAC03 output module.**

2.3 INSTALLATION

The following paragraph provides detailed instructions for installing the basic Versimux™ configuration.

2.3.1 CHASSIS INSTALLATION

Install the Versimux™ chassis in a 19-inch rack using standard mounting hardware. The chassis requires 8 ¾ inches of vertical mounting space and should not be located adjacent to equipment that generates excessive heat.

2.3.2 CAM-1 CARD

The Versimux™ chassis is equipped with ZIF (zero insertion force) connectors. To open the connector, pull the handle out approximately ½ inch and turn the handle 90° clockwise. The connector will remain in the open position. Insert the CAM-1 card in the slot 1 (extreme left) position with the component side to the right. Verify that the bottom rear of the card is against the stop plate at the bottom rear of the chassis. Return the connector handle to its original position to close the connector.

Note: To prevent dirt and natural oil from being deposited on the contacts, avoid touching the card contacts along the top edge of the card.

2.3.3 PORT CARDS

Install individual port cards in the chassis by simply opening the connector, inserting the card, and closing the connector. The port cards may be installed in any slot in the chassis: however, the slot position for a particular port must be the same at both the local and remote chassis.

Note: To prevent breaking the stop plate on the ZIF connectors, the connectors should be in the open position before attaching cables to the rear of the card.

2.3.4 FIBER OPTIC INTERFACE

The CAM-1 card is equipped with ST type connectors for interfacing to the fiber optic cable. When installing the fiber optic cable, make certain the output from the local unit is connected to the input at the remote unit.

2.3.5 OPERATING POWER

The Versimux™ is supplied with two power cords that attach to the input power modules located in the rear of the chassis. The power cords should be connected to separately fused mains. Before connecting the power, verify that the power selection switches (located on the power output modules) are set to the proper position.

2.3.6 INTERFACE CABLING

In the OMC-14 chassis the center-to-center card spacing is 7/8 inch. This allows a maximum hood width of 13/16 of an inch to maintain 1/16 of an inch clearance.

2.3.7 REMOTE CONTROL/STATUS PANEL INTERFACE

The Versimux™ may be equipped with an optional, customer supplied, remote control status panel to monitor power supply and alarm status. Interface connections are made to the 9-pin connector located on the power supply input module. This connector should be wired in accordance with Table 2-1.

Pin Designation	Signal	Function Designation
1	-12 Volts	Operating Voltages for Remote Control/Status Panel
2	-6 Volts	
3	Ground	
4	+6 Volts	
5	+12 Volts	
6	Normally Open	Connection will be made between Normally Open and Common during Alarm
7	Common	
8	Normally Closed	
9	Remote Test	Normally high; ground will activate Alarm test

**Table 2-1 Remote Control/
Status Indicator**

CHAPTER 3 OPERATION

3.1 INTRODUCTION

This section contains operating instructions for the basic Versimux™ unit. Please refer to the appropriate VERSITRON instruction manual for information on the individual port cards.

3.2 POWER SUPPLY OUTPUT MODULE

Each power supply output module contains a status indicator, an audible alarm, a three-position alarm toggle switch, and a two-position power selection switch. During normal operation, the alarm switch on both modules should be set to the alarm position to activate the alarm detection circuitry. The status lamp on both modules should be on, providing a positive indication of normal operation in both circuits.

A loss of input power, positive operating voltage, or negative operating voltage in either power circuit will cause an alarm condition. During an alarm condition, the audible alarm will sound and the status lamp will remain on in the operating module, indicating that the module is operating satisfactorily. In the defective module, the status lamp will go out to identify the defective module.

Setting the alarm switch on the operating module to the Mute position may mute the audible alarm. This will cause its status lamp to go out, indicating the power supplies are not at full capability.

Setting the switch to the Test position may check the alarm detection circuitry. The audible alarm should be activated and the status lamp should go out. This test also checks the alarm detection circuitry on each port module installed in the chassis. In the Test mode all power indicators should go off and all out-of-sync indicator should come on. Note that this test does not interrupt traffic. All Alarm functions may also be controlled from a remote panel. Refer to paragraph 2.3.7.

3.3 POWER SUPPLY INPUT MODULE

The input module, located at the rear of the chassis, contains a status indicator. This LED should be on at all time, indicating that both positive and negative operating voltages are present.

3.4 CAM-1 CARD

The CAM-1 card does not contain any operator controls. The two status indicators, located at the top of the card, are described below.

PWR CAM-1 (green). This lamp provides a positive indication that positive and negative operating voltages, from both power circuits, are present on the card. An off condition indicates a malfunction either in one of the power modules or in one of the dual power circuits on the card. If the PWR lamps on all the cards are off the malfunction is in a power module.

Note: The CAM-1 card will continue to operate with a malfunction in either a power module or a power circuit on the card, as long as the second circuit is functional.

OUT SYN (red). This lamp indicates that the receiver has lost synchronization. This lamp should be off for normal operation.

IMPORTANT WARNING: Turn power “off” prior to removing a CAM card for any reason.

CHAPTER 4 SYSTEM CONFIGURATIONS

4.1 GENERAL

This section provides general information on typical operating configurations for the Versimux™. Paragraph 4.2 describes typical configurations for the digital port cards, paragraph 4.3 describes the telephone port cards.

4.2 DIGITAL PORT CARDS

Most of the digital port cards may be used to provide either a modem link or an interface extension. Additionally, some port cards may be used to provide interface conversion as well as the fiber optic link.

Figure 4-1 illustrates typical configurations for the MP908 port card. In the first configuration an MP908 port card is used at both the local and remote Versimux™ chassis to provide a 449/449 link.

4.3 TELEPHONE PORT CONFIGURATIONS

Figure 4-2 illustrates typical configurations for the telephone port cards. In the first configuration an MP9711 is used at both the local and remote chassis to provide two full-duplex subscriber links. In the second configuration the remote chassis is equipped with an MP9701 card to provide a dual interface to the exchange. If an MP9721 card is used at the remote chassis, both a subscriber link and an exchange link will be provided.

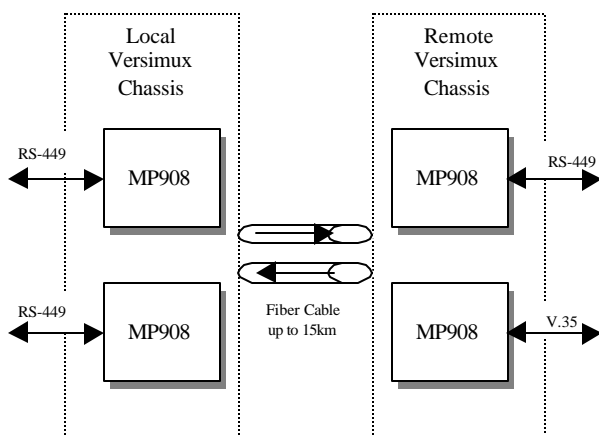

Figure 4-1
Typical Digital Port Configuration

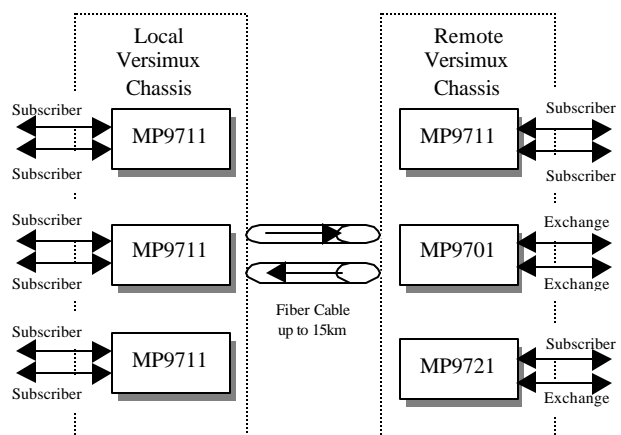

Figure 4-2
Typical Telephone Port Configuration

CHAPTER 5 MAINTENANCE AND TROUBLESHOOTING

5.1 ROUTINE MAINTENANCE

5.1.1 INTRODUCTION

Many routine maintenance procedures are neither necessary nor desirable with the Versimux™ equipment. Very few impending faults will be evident during overhaul, and the stresses imposed upon the equipment during an old-style overhaul will certainly reduce reliability. Below are the recommended routine maintenance procedures:

5.1.2 INSPECTION

Inspect both ends of the Versimux link:

- All green card power indicators should be on.
- Both red power supply indicators should be on.
- No red sync indicators should be on.
- Data and control indicators may flash if in use.
- Check fan operation.
- Check operation of power alarm by removing each input power lead in turn (not at same time). System should function normally, but give instant audible and visual alarm.

NOTE:

If all the above can be performed with the front door of the enclosure closed, then the link is performing normally.

5.2 ROUTINE SERVICE

5.2.1 INTRODUCTION

The following procedures require that the Versimux™ enclosure is opened.

5.2.2 TEST

The test is performed on the link as a whole:

- De-commission Versimux link.
- Open the front panel.
- Test the alarm facilities by depressing the switch on each power supply output module in turn. Make sure that the switch is completely returned to the up position.

5.2.2 TEST (cont'd)

- Depress the test switch on all port cards. After a settling period of about 1 second, ensure that the “test error” indicator is off. Push the “error inject” button on each card, in order, verifying the “test error” indicator lights are working properly.

5.3 TROUBLESHOOTING

5.3.1 FAULT FINDING

Faults on the Versimux™ are very infrequent, and are mostly accompanied by alarms and visual indicators allowing easy localization of problems. The operation of the Versimux™ fault diagnostics are given below:

Audible Alarm

Indicates one or the following:

- Loss of one power supply.
- Loss of card power.
- Loss of control data frame sync.
- Loss of data frame sync.
- Loss of received IR signal

Visual Alarm

Red LED'S:

With the exception of the indicators on the power supplies that should be permanently on, any red light indicates malfunction. Note: A complete loss of input signal is indicated by all “sync” indicators on and, that a fault indicated on one card may indicate a problem with the corresponding card in the remote Versimux™.

Amber LED'S:

These indicate data flow functions and are useful for indicating the status of the attached terminal equipment. Note: Most faults occurring in a system, of which, the Versimux™ is a part will be due to the terminal's equipment. The amber LED's are useful data monitor points.

Green LED's:

Card Power Indicators: Shows loss of card power, which may, in part, be due to a failure of a card fuse or an integral card regulator.

5.3.2 BUILT-IN TEST CAPABILITY

Many cards are equipped with a self-test capability. This feature is designed to test much of the circuitry on both the local and corresponding remote port cards as possible. Refer to the following two test procedures:

1. To perform a diagnostic loop test simply set the test/operate switch (S2) to the TEST (up) position. In the test mode the local port card will generate a pseudo-random pattern and transmit it to the remote port card in lieu of the data signal (see Figure 5-1). At the remote port card the signal is recovered and looped back as SEND DATA. The pattern detector at the local unit will activate the TEST ERR lamp if a discrepancy is detected between the original pattern and the recovered pattern. The operation of the test circuitry may be verified by momentarily depressing the Error Insert pushbutton. This will cause an error to be inserted into the test pattern. When the error is detected the TEST ERR lamp will be turned on.

2. To perform a diagnostic end-to-end test simply set the test/operate switch (S2) to the TEST (up) position on both local and remote port cards. In the test mode the local port card will generate a pseudo-random pattern and transmit it to the remote port card in lieu of the data signal (see Figure 5-2). At the remote port card the signal is recovered, the pattern detector will activate the TEST ERR lamp if a discrepancy is detected between the local pattern and the recovered pattern. The operation of the test circuitry may be verified by momentarily depressing the Error Inset pushbutton. This will cause an error to be inserted into the test pattern from the local card causing the remote TEST ERR lamp to turn on.

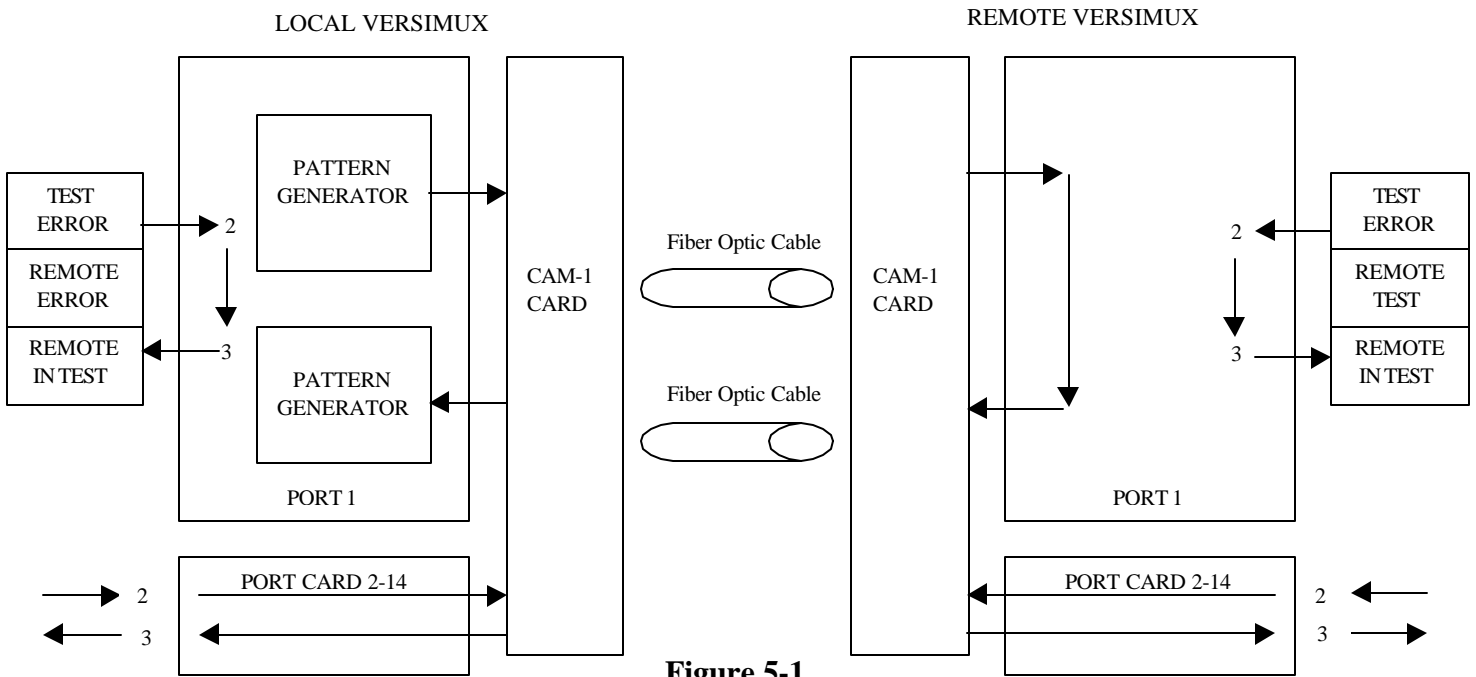

Figure 5-1
Signal Path, Local Unit in Test Mode

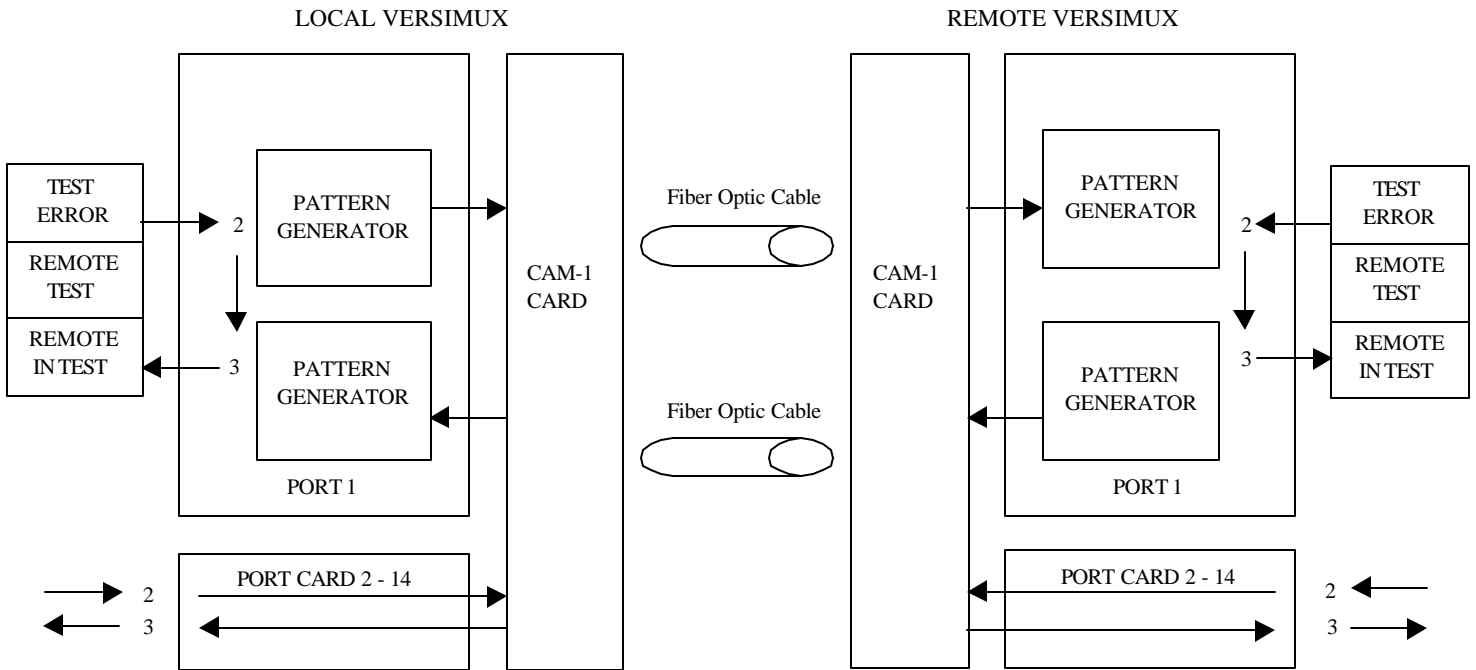

Figure 5-2
Signal Path, Local and Remote Unit in Test Mode

5.4 MODULE FAULT LIABILITY

Enclosure and Chassis:

The enclosure/chassis assembly contains few mechanical or electrical parts requiring maintenance.

Power Supplies:

If a power supply failure should occur, suspect the fuse on the PS-I/P module. A constantly blowing fuse is most likely caused by an abnormal load condition, suspect a short circuit caused by an incorrectly inserted circuit card. If all circuit cards are correctly positioned, suspect a transformer failure in the PS-O/P module.

Mother Board:

The only likely fault on the motherboard is damage to the ZIF edge connectors. This can occur by attempting to connect ports while the ZIF connector is closed, and by closing the ZIF connector on a card that is not fully inserted.

CAM 1 and Port Cards:

Other than fuses, no component has any notable fault liability.

5.4 MODULE FAULT LIABILITY (cont'd)

Fiber Optic Cable:

Being made out of glass, there are restrictions on the amount of bending that the fiber can withstand. Never stress the cable or bend it around tight corners. Observe a minimum bend radius of four inches.

5.4.1 FAULT FINDING GUIDE

Step 1: Are the Power Indicators on Both Power Supplies On?

If Yes, then go to Step 2

If No, then go to Step 10

Step 2: Are the Power Indicators of All Cards On?

If Yes, then go to Step 3

If No, then go to Step 11

Step 3: Is the CAM 1 Sync Indicator On?

If Yes, then go to Step 12

If No, then go to Step 4

Step 4: Are All the Port Sync Indicators On?

If Yes, then go to Step 13

If No, then go to Step 5

Step 5: Is One Port Sync Indicator On?

If Yes, then go to Step 14

If No, then go to Step 6

Step 6: Are There Corruptions or Loss of Communications on all ports?

If Yes, then to Step 15

If No, then to Step 7

Step 7: Are there Corruptions or Loss of Communications on one port?

If Yes, then go to Step 16

If No, then go to Step 8

Step 8: Fault Apparent Only on Test?

If Yes, then go to Step 17

If No, then go to Step 9

Step 9: Intermittent Fault?

Go to Step 18

5.4.2 FAULT ISOLATION

If directed to this section, perform tests in sequence until fault is rectified.

Step 10: Power Supply Fault

- Check that power input to PS-I/P module is present, and within limits. Note that the top PS-I/P module supplies the top output module, and is fed (in the case of R-series chassis) from the right hand side (viewed from rear) power input filter.
- Remove PS-I/P module and replace fuse if blown.
- Replace Output module
- Replace Input module

An incorrectly inserted port card can cause abnormal loads on the power supply with consequent continual fuse blowing.

Step 11: Card Power Failure

Assuming only one card displays loss of power.

- Remove card and check four fuses
- Replace card

Step 12: Loss of Data Frame Sync

May be due to loss of received signal, corrupt signal received from remote Versimux™, or CAM 1 fault.

- Loop the CAM 1 optical fiber output back to its input with a short length of fiber. If fault indication persists, CAM 1 is faulty.
- Reverse optical fibers of data link at both local and remote Versimux™. If fault symptoms are now present on the other Versimux™, optical fiber is faulty.
- Loop optical input and output of remote CAM 1. If remote Versimux™ now displays fault, remote CAM 1 is faulty.

Step 13: Control Aggregate Data Error

- Replace remote CAM 1
- Replace local CAM 1
- Release each ZIF port edge connector of remote Versimux.™ If fault indication disappears, replace port card.
- Release each local port card ZIF connector. Replace card when fault disappears.

5.4.2 FAULT ISOLATION (cont'd)

Step 14: Port Sub-Multiplex Function Fault

- Replace port card displaying fault.
- Replace corresponding port card in remote Versimux™.

Step 15: Total System Corrupt or Inhibited

If accompanied by CAM 1 sync indicator on, Go to Step 12.

If accompanied by port card sync indicators (only), Go to Step 13.

Assuming power indicators normal.

- Replace local CAM 1.
- Replace remote CAM 1.
- Release port card ZIF connectors individually until normality returns.

Step 16: Port Corrupt or Inhibited

- If fitted, use port self-test facilities. If test sequence is without error, monitor card indicators to establish presence of data and control functions from terminal.
- Check terminal equipment by transferring them to an adjacent channel.
- Replace local or remote port card as necessary.
- Replace local or remote CAM 1 as necessary.

Step 17: Fault Apparent Only on Test

- Replace port card.
- Replace port card.
- Replace remote port card.

Step 18: Intermittent Faults

Procedure dependent upon the nature of the fault.

- Each fault will indicate a probable faulty system component. This card or module must be replaced, and the performance of the system observed over a period of time which is considerably longer than the average period between faults, until a fully functioning system is returned. Never replace more than one board at a time, and if the replacement of a board does not cure the fault return the original board to its position.