

**M8000 Series
Fiber Optic MicroModem
Technical Manual**

RS-232

Revision A

Copyright Oct 2002

**VERSITRON, Inc.
83 Albe Drive / Suite C
Newark, DE 19702
www.versitron.com**

A021030275

PROPRIETARY DATA

All data in this manual is proprietary and may not be disclosed, used or duplicated, for procurement or manufacturing purposes, without prior written permission by **VERSITRON**.

WARRANTY

All VERSITRON products purchased after January 2001 carry a limited lifetime warranty against defects in materials and workmanship for the lifetime of the product. Purchases made prior to January 2001 are warranted for a period of one year from date of delivery. VERSITRON reserves the right to repair or, at our option, replace parts which during normal usage prove to be defective during the warranty period provided that:

1. You call VERSITRON at (302) 894-0699 or (800) 537-2296 and obtain a (RMA) Return Authorization Number. Please reference your RMA number on the outside of the box in which the item is returned.
2. Shipping charges are pre-paid.

No other warranty is expressed or implied and we are not liable for consequential damages. For repairs outside of the warranty period, the same procedure must be followed.

TABLE OF CONTENTS

PARAGRAPH	TITLE	PAGE
SECTION 1: DESCRIPTION OF EQUIPMENT		
1.1	INTRODUCTION.....	1
1.2	DESCRIPTION OF EQUIPMENT	1
1.2.1	Functional Characteristics.....	1
1.2.2	Physical Characteristics.....	2
1.3	SPECIFICATIONS	4
SECTION 2: INSTALLATION		
2.1	GENERAL.....	5
2.2	SITE SELECTION AND MOUNTING	5
2.2.1	Signal Interface.....	5
2.2.2	User Selected Options.....	5
2.3	POWER REQUIREMENTS	5
2.3.1	Installation With AC Power	6
2.3.2	Installation With DC Power	6
2.4	INITIAL CHECKOUT PROCEDURE.....	6
SECTION 3: OPERATION		
3.1	INTRODUCTION.....	7
3.2	STATUS INDICATORS/ALARM.....	7
3.3	OPERATING CONTROLS.....	7
SECTION 4: THEORY OF OPERATION		
4.1	INTRODUCTION.....	8
SECTION 5: MAINTENANCE AND TROUBLESHOOTING		
5.1	INTRODUCTION.....	9
5.2	FAULT ISOLATION	9

LIST OF ILLUSTRATIONS

FIGURE	TITLE	PAGE
1.	OVERALL VIEW, M8000 SERIES MICROMODEM.....	2
2.	INTERFACE EXTENDER CONFIGURATION.....	3
3.	MODEM LINK CONFIGURATION	3
4.	OVERALL VIEW, MRR-16 CHASSIS.	5
5.	EIA/MIL SWITCH SETTINGS.....	6

SECTION 1

DESCRIPTION OF EQUIPMENT

1.1 INTRODUCTION

This manual provides general and detailed information on the installation and operation of the M8000 Series MicroModems. Section 1 contains a general description of the equipment. Section 2 contains installation instructions. Section 3 contains operating instructions. Section 4 provides the theory of operation. Section 5 contains maintenance and troubleshooting information.

Model Number	Part Number	Description
M8213	30275-22	RS-232, multimode, 850nm optics, ST connectors, <i>DCE</i> , 2 Km operational distance.
M8214	30275-24	RS-232, multimode, 1300nm optics, ST connectors, <i>DCE</i> , 8 Km operational distance.
M8215	30275-25	RS-232, single mode, 1300nm optics, ST connectors, <i>DCE</i> , 15 Km operational distance.
M8223	30275-12	RS-232, multimode, 850nm optics, ST connectors, <i>DTE</i> , 2 Km operational distance.
M8224	30275-14	RS-232, multimode, 1300nm optics, ST connectors, <i>DTE</i> , 8 Km operational distance.
M8225	30275-15	RS-232, single mode, 1300nm optics, ST connectors, <i>DTE</i> , 15 Km operational distance.

1.2 DESCRIPTION OF EQUIPMENT

1.2.1 Functional Characteristics

The M8000 Series MicroModems (Figure 1) provide copper-to-fiber conversion for data transmission over fiber optic cable as interface extenders (Figure 2) or as modem links (Figure 3) for synchronous or asynchronous data. M8213 and M8223 modems are equipped with multimode 850nm LED optics and can transmit over a pair of multimode fiber cables for up to 2 Km (6,600 ft). M8214 and M8224 modems are equipped with multimode 1300nm LED optics and can transmit over a pair of multimode fiber cables for up to 8 Km (26,400 ft). M8215 and M8225 modems are equipped with single mode 1300nm LED optics and can transmit over a pair of single mode fiber cables for up to 15 Km (49,500 ft). The link is fully transparent in both directions at any data rate from 1 Bps to 100 Kbps with terminal timing or from 1 Bps to 64 Kbps with source timing. Interface control signals associated with RS-232 are fully supported. This is accomplished by multiplexing the control signals along with the clock and data signals and transmitting the combined signal to the remote unit. At the remote end the combined signal is demultiplexed and applied to the interface.

1.2.2 Physical Characteristics

The M8000 Series MicroModems measure 2.5 x 1.0 x 4.5 in. (6.35 x 2.54 x 11.43 cm.) (HWL). Housed in extruded aluminum, these modems are self-contained and may be mounted directly to electrical interface connectors. Model M821x is a DCE unit with a female DB25 for connecting to a terminal electrical interface. Model M822x is a DTE unit with a male DB25 for connecting to a modem electrical interface. ('x' is replaced with '3' for MM 850nm optics, '4' for MM 1300nm optics or '5' for SM 1300nm optics.) ST optical connectors are standard for all models with the transmitter optic located closest to the power jack.



FIGURE 1. OVERALL VIEW, M8000 SERIES MICROMODEM

M8000 Series MicroModems require DC power for operation, with a one-pin connector for electrical input. DC power (+5 to +15 VDC) may be applied to the power jack if providing power from a DC source or to pin 9 of the DB25 interface if utilizing host power. Otherwise, an external power adapter is available for converting VAC to VDC. Reference Section 2.3 for more information.

The MRR-16 is a 19" standard rack mount chassis available for mounting and providing power for up to 16 MicroModems (Figure 4). The MRR-16 measures 19 x 3.5 x 11.2 in. (48.3 x 8.9 x 28.4 cm.). Power supply Model M0004 provides DC power to the chassis from an AC power source. Two power supplies are recommended for power redundancy. The M0004 measures 1.3 x 2.5 x 5.1 in. (3.33 x 6.35 x 13.02 cm.) and although it is not designed for chassis mounting, it is small enough to be secured in the chassis if so desired. The M0004 supplies provide power to the MRR-16 chassis power bus bar. From the bus bar, power is provided to each MicroModem by a 6" Model M0001 power jumper cable. Please note that each MicroModem requires its own M0001 power cable.

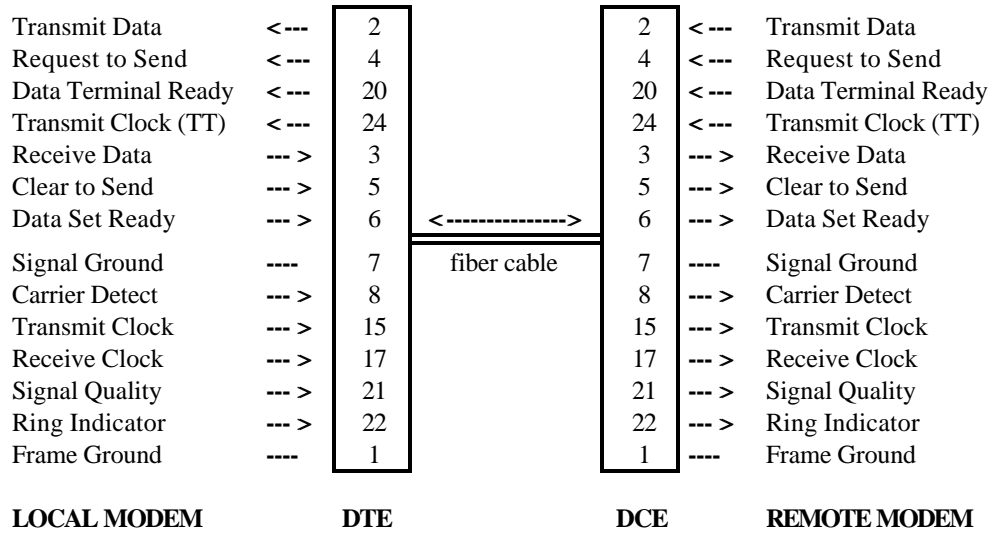

FIGURE 2. INTERFACE EXTENDER CONFIGURATION

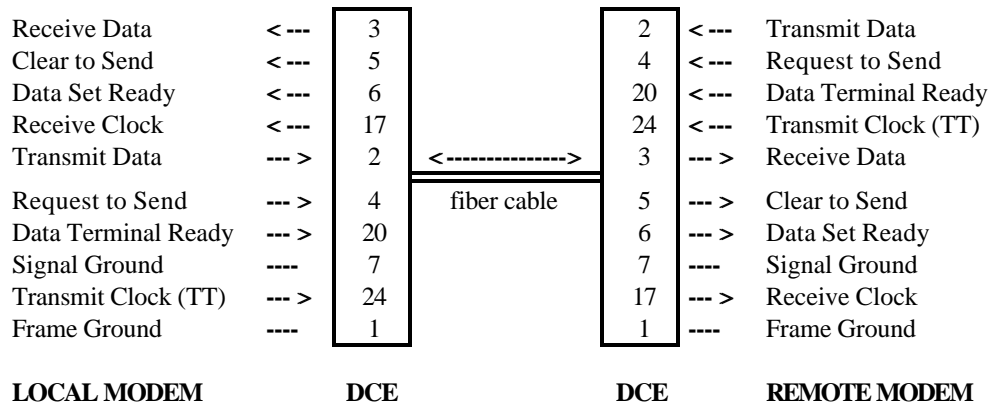

FIGURE 3. MODEM LINK CONFIGURATION

1.3 SPECIFICATIONS

Data Signal: Signal levels and format conform to RS-232.

Data Rate: Source Timing - continuously variable from 1 Bps to 64 Kbps for synchronous or asynchronous signals.

Terminal Timing - continuously variable from 1 Bps to 100 Kbps for synchronous or asynchronous signals.

Operating Mode/Range: Full duplex or simplex operation over a fiber optic cable pair with maximum range of 2 Km (6,600 ft) for 850nm multimode, 8 Km (26,400 ft) for 1300nm multimode, and 15 Km (49,500 ft.) for 1300nm single mode.

Optical Interface:

Models	M8213/M8223	M8214/M8224	M8215/M8225
Wavelength	Multimode 850nm	Multimode 1300nm	Single Mode 1300nm
Connector	ST	ST	ST
Link Budget	20 ± 1 dB	18 ± 1 dB	18 ± 1 dB
Maximum Range	2 Km	8 Km	15 Km
Fiber Optic Cable	50/125, 62.5/125, 100/140	50/125, 62.5/125,100/140	8/125, 9/125,10/125

Note: Multimode tests were performed on 62.5/125 μM fiber optic cable.

Single Mode tests were performed on 9/125 μM fiber optic cable.

Electrical Connector: DCE - DB25 female for terminal interface connections.

DTE - DB25 male for modem interface connections.

Bit Error Rate: Better than 10⁻⁹.

Sampling Rate: 300 KHz (clock and data), 18.75 KHz (control lines). When asynchronous data is applied to control lines, there is approximately 5% jitter at a data rate of 1 Kbps.

Dimensions: 2.5 x 1.0 x 4.5 in. (6.35 x 2.54 x 11.43 cm.) (HWL)

Weight: 6.0 oz (0.17 kg)

Power Requirements: 115/230 VAC, 1.4 Watts, with power adapter providing 12 VDC, 1A (Model PSAC08, US; Model PSAC09, European).

Environment: 0° to +50°C (32° to +122°F) operating temperature; up to 95% relative humidity (non-condensing); up to 10,000ft altitude; storage temperature -40° to +70°C.

SECTION 2 INSTALLATION

2.1 GENERAL

This section contains information on installation and checkout of the M8000 Series MicroModems. Paragraph 2.2 contains general information on site selection and rack mounting. Paragraph 2.3 contains instructions for connecting the MicroModems to your system and selecting options. Paragraph 2.4 contains initial checkout procedures.

2.2 SITE SELECTION AND MOUNTING

The M8000 Series MicroModems connect to the electrical interface with two hand-tightened screws. When mounting to a PC, facsimile equipment or STU III telephone, securely position the MicroModems allowing space for each power adapter, if used. When rack mounting, up to 16 MicroModems may be installed in the MRR-16 rack mount chassis (Figure 4). The chassis measures 19.0 x 3.5 x 11.2 in. (48.3 x 8.9 x 28.4 cm.). The Model M0004 power supply provides DC power to the chassis from an AC power source. Dual M0004 power supplies may be installed to provide redundancy. In this configuration, 6" power jumper cables (Model M0001) are required to provide power to each MicroModem installed.



FIGURE 4. OVERALL VIEW, MRR-16 CHASSIS

2.2.1 Signal Interface

DCE MicroModems have DB25 female connectors for terminal interface connections. DTE MicroModems have DB25 male connectors for the interface connections.

2.2.2 User Selected Options

An internal switch, SW1, is provided to select EIA or MIL operation (Figure 5). Default settings for SW1 Positions 1, 2, 3, 4 and 6 are OFF; Positions 5, 7 and 8 are ON. With switch position 7 in the ON position, operation for EIA is set. With switch position 7 in the OFF position, operation for MIL is set. By selecting EIA on one end of the link and MIL on the other, interface conversion occurs. The rest of the switches on the unit are for diagnostic purposes only and should not be moved by the user.

2.3 POWER REQUIREMENTS

M8000 Series MicroModems operate from either an AC/DC power adapter or a DC power source with DC voltage of +5 to +15 VDC. Power adapters needed are Models PSAC08 for 115 VAC input (US) or PSAC09 for 230 VAC input (VDE). Host power may also be used by providing power to pin 9 of the DB25 connector.

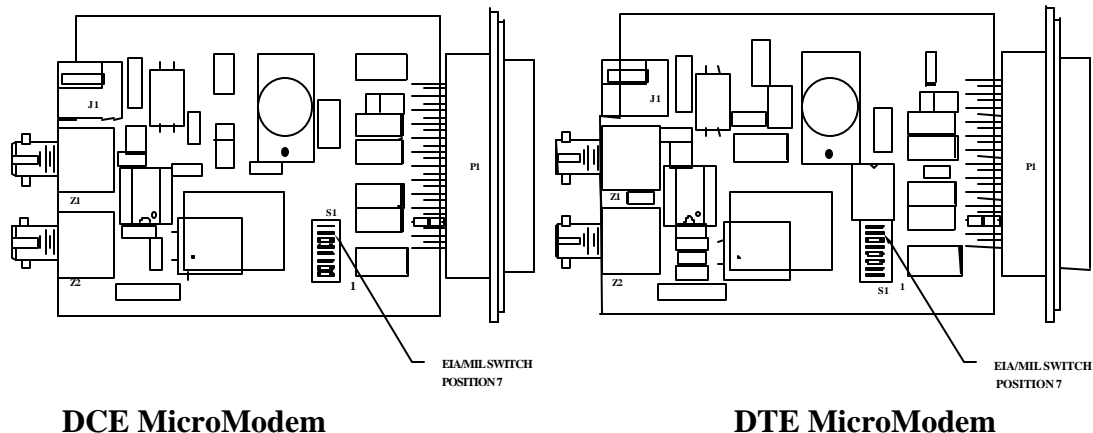

FIGURE 5. SWITCH SETTINGS

2.3.1 Installation with AC Power

Connect the power adapter to the MicroModem before inserting its plug into an AC power source. There are no special tools required.

2.3.2 Installation with DC Power

DC input may be used in lieu of an AC/DC transformer. This requires a 2.5 mm socket with the positive on the center and common on the concentric, and providing +12 VDC at 250mA. DC power may be provided directly to the power jack or host power may be provided to pin 9 of the DB25 connector. DC voltage input can range from +5 to +15 VDC.

2.4 INITIAL CHECKOUT PROCEDURE

MicroModems contain no power on/off switch. The unit is fully operational once installed and power is applied. Before beginning operation verify the following:

1. MIL/EIA switch is set for your configuration: ON for EIA, OFF for MIL. Please note that the factory setting is ON for EIA.
2. Fiber cable is "crossed" (connected from transmit to receive from one unit to the other). Note that the transmitter is closest to the power connector.
3. Power plug is seated fully into the MicroModem or in the chassis.

If a malfunction is detected during the initial checkout procedure, refer to Chapter 5 for information on isolating the malfunction in the unit.

SECTION 3 OPERATION

3.1 INTRODUCTION

This chapter contains a description of the operating controls and indicators associated with the M6000 Series MicroModems. Since the MicroModems are designed for continuous and uninterrupted operation, there are no operating requirements. Once power is applied, the MicroModems should remain in service as long as required.

3.2 STATUS INDICATORS/AUDIBLE ALARM

There are no status indicators or audible alarms associated with the M6000 Series MicroModem. If these features are required, VERSITRON Series FOM II fiber optic modems provide LED indicators and other features for monitoring the circuit. Refer to <http://www.versitron.com/RS232FOM.html> for additional information.

3.3 OPERATING CONTROLS

The only operating control associated with the M8000 Series MicroModems is an internal switch used to select between RS-232 and MIL-STD-188C. Factory setting is for RS-232 unless requested otherwise prior to shipping. Further changes are not required unless the system requirements change.

SECTION 4

THEORY OF OPERATION

4.1 INTRODUCTION

Operation of the M8000 Series MicroModems is similar to a four-channel, full duplex multiplexer. The first channel is used for data. The next two channels are used for transmit and receive clock, while the fourth multiplexer channel is used for aggregated control signals. This technique provides full transparency for the link, even when both clocks originate at the MicroModem. The MicroModem supplies both transmit and receive clocks which are transmitted through the link and applied directly to the terminal.

The interface control signals are processed in a similar manner. The Request to Send signal from the terminal is transmitted through the link and applied to the MicroModem. When the MicroModem responds with Clear to Send, it will be transmitted through the link and applied to the terminal. With this technique, the terminal will see the RTS/CTS delay established by the MicroModem.

If a fully transparent synchronous link is not required, the clock and control paths may be used as additional asynchronous data paths. The transmit and receive clock inputs will handle data rates from 0 to 64 Kbps asynchronously; the control paths will handle data rates up to 1 Kbps with 10-20% distortion.

SECTION 5

MAINTENANCE AND TROUBLESHOOTING

5.1 INTRODUCTION

This chapter contains general information designed to isolate a malfunction in an application involving the M8000 Series MicroModem to a replaceable unit. These units are not equipped with redundancy. Therefore, a failure in one of these units would interrupt service.

5.2 FAULT ISOLATION

There are no status indicators on the MicroModems. If a malfunction is suspected then performing the following steps may help to determine where a problem in the link may be located. Confirm that the signal pinouts of the MicroModems match the signal pinouts desired for the equipment to which the units are connected. To verify optical output, you must remove the transmit fiber optic cable to verify that the unit is emitting light (transmitting). The transmitter optic is located closest to the power jack. If both units are emitting light check that each fiber optic cable is crossed transmit to receive. If no light is present then check the power adapter plug for proper seating and that power is supplied to the unit. Check Pin 9 of the DB25 connector for power input if host power is being used. If light is still not present, swap power adapters to check for a bad adapter. Testing of the fiber optic cable may also be necessary to confirm the link budget of the cable.

If data is inverted on one end of the link, check the EIA/MIL switch for correct placement. The data will be inverted relative to the associated clock.

If you are still experiencing problems, contact VERSITRON customer service for assistance. (302) 894-0699 or (800) 537-2296.