



M7260M
10/100/1000BASE-T to 1000BASE-X
MEDIA CONVERTER WITH SFP SUPPORT
&
WEB SMART MANAGEMENT

INSTALLATION GUIDE

© September 2006

VERSITRON, Inc.
83 Albe Drive - Suite C
Newark, DE 19702
www.versitron.com

PROPRIETARY DATA

All data in this manual is proprietary and may not be disclosed, used or duplicated, for procurement or manufacturing purposes, without prior written permission by **VERSITRON, Inc.**

All VERSITRON products are covered by a *Lifetime Warranty* against defects in materials and workmanship. This coverage is applicable to the original purchaser and is not transferable.

We repair, or at our option, replace parts/products that, during normal usage and operation, are proven to be defective during the time you own the products, provided that said products and parts are still manufactured and/or available.

This warranty does not cover damage to products caused by misuse, mishandling, power surges, accident, improper installation, neglect, alteration, improper maintenance, or other causes which are not normal and customary application of the products and for which they were not intended. No other warranty is expressed or implied, and VERSITRON is not liable for direct, indirect, incidental or consequential damages or losses.

In the unlikely event a warranty issue should arise, simply contact us at 302-894-0699 or 1-800-537-2296 or via email to fiberlink@versitron.com and obtain a Return Material Authorization (RMA) number. Reference this number on the outside of the shipping container and return the unit (shipping charges prepaid) to us for diagnostic review and repair/replacement as determined solely by VERSITRON. We pay the shipping charges to return the repaired unit or a replacement unit to you.

The information contained in this document is subject to change without prior notice. Copyright ©. All Rights Reserved.

TRADEMARKS

Ethernet is a registered trademark of Xerox Corp.

WARNING:

This equipment has been tested and found to comply with the limits for a Class A digital device, pursuant to Part 15 of the FCC Rules. These limits are designed to provide reasonable protection against harmful interference when the equipment is operated in a commercial environment. This equipment generates, uses, and can radiate radio frequency energy and if not installed and used in accordance with the instruction manual may cause harmful interference in which case the user will be required to correct the interference at his/her own expense.

NOTICE:

- (1) The changes or modifications not expressly approved by the party responsible for compliance could void the user's authority to operate the equipment.
- (2) Shielded interface cables and AC power cord, if any, must be used in order to comply with the emission limits.

CISPR COMPLIANCE:

This device complies with EMC directive of the European Community and meets or exceeds the following technical standard.

EN 55022 - Limits and Methods of Measurement of Radio Interference Characteristics of Information Technology Equipment. This device complies with CISPR Class A.

WARNING: This is a Class A product. In a domestic environment this product may cause radio interference in which case the user may be required to take adequate measures.

CE NOTICE

Marking by the symbol  indicates compliance of this equipment to the EMC directive of the European Community. Such marking is indicative that this equipment meets or exceeds the following technical standards:

EN 55022: Limits and Methods of Measurement of Radio Interference characteristics of Information Technology Equipment.

EN 50082/1: Generic Immunity Standard -Part 1: Domestic Commercial and Light Industry.

EN 60555-2: Disturbances in supply systems caused by household appliances and similar electrical equipment - Part 2: Harmonics.

Table of Contents

1. Introduction	6
1.1 Features	7
1.2 Product Panels	8
1.3 Specifications	8
2. Installation	11
2.1 Package Contents.....	11
2.2 Safety Cautions	11
2.3 Mounting the Media Converter	12
2.4 Applying Power	13
2.5 Making UTP Connections	14
2.6 Making Fiber Connection	15
2.7 Loopback Test Push Button	16
2.8 Configuration DIP SW	17
2.9 LED Indication	18
2.10 Configuring IP Address and Password for the Device	19
3. Functions	20
3.1 Abbreviation	20
3.2 Converter Function	20
3.3 Link Fault Pass Through Function	21
3.4 Remote TP Status Monitoring Function.....	22
3.5 802.1Q Control Function	23
3.6 QoS Function	25
3.6.1 Packet Priority Classification	26
3.6.2 Priority Class Queues	26
3.6.3 Egress Service Policy	26
3.7 SNMP Trap Function.....	27
4. Web Management	28
4.1 Start Browser Software and Making Connection	28
4.2 Login to the Device Unit	28
4.3 Main Management Menu	29
4.4 System	30
4.4.1 Management VLAN	32
4.5 Ports	33
4.5.1 802.1Q Filtering	36
4.5.2 802.1p Mapping	37
4.5.3 DSCP Mapping	38
4.6 Statistics	39
4.7 Loopback Test	40

4.8 Reboot System	40
4.9 Restore Default	40
4.10 Update Firmware	41
4.11 Logout	41
Appendix A. Factory Default Settings	42
Appendix B. Models & Optical Specifications	44

1. Introduction

The M7260M is a Gigabit Ethernet media converter series which provide the following features:



Data Conversion between different Media types and Speed

The media converter supports the following conversions:

- 1000Mbps (1000BASE-T) copper to/from 1000Mbps (1000BASE-X) fiber
- 100Mbps (1000BASE-TX) copper to/from 1000Mbps (1000BASE-X) fiber
- 10Mbps (10BASE-T) copper to/from 1000Mbps (1000BASE-X) fiber

Mini-GBIC (SFP) Fiber Connectivity

The mini-GBIC (SFP) port can be installed with different optional SFP optical fiber transceiver to support multi-mode or single-mode fiber for short reach up to long reach distance.

Loopback Test Support

The media converter provides loopback test function which can verify the fiber link with its link partner by sending test packets to the link partner and verifying the echo packets sent back. This feature is helpful in checking connection quality of fiber link during installation.

Link Fault Pass-Through

This feature can force the link to shut down as soon as it notices that the other link has failed. It allows a link partner on one cable segment can notice a link fault occurred on the other segment and give application a chance to react.

Remote TP Port Status Monitoring

When two devices are connected together via a fiber link, the device can monitor and display the twisted-pair port status of the remote fiber link partner. The status display can be on the local LED indicators or web management interface.

802.1Q Control

With software configuration support, the device is enhanced with more 802.1Q control features for VLAN applications rather than just a typical media converter function. The optional features include:

- Filtering all untagged packets
- Filtering all tagged packets
- Filtering tagged packets with certain VID
- Packet Tag removal (Untagging)
- Packet Tag insertion (Tagging)

Quality of Service

For conversion between two different speeds, the device is featured with powerful Quality of Service (QoS) function which can classify the priority for received network frames based on the ingress port and frame contents. Furthermore, many service priority policies can be configured for egress operation.

Web Management

The device is embedded with an Http server which provides management functions for advanced network functions including Port Control, Quality of Service, and Virtual LAN functions. The management can be performed via a Web browser based interface over TCP/IP network.

1.1 Features

Basic functions

- Provides tri-speed 10/100/1000Mbps copper to 1000Mbps fiber conversion
- Provides mini-GBIC SFP support
- Support full wire speed Gigabit copper to Gigabit fiber conversion
- The copper port supports auto-negotiation and auto-MDI/MDI-X detection
- Copper port auto-negotiation mode, speed and duplex configuration by DIP switch settings
- Allows link fault status passes through between copper link and fiber link transparently.
- Far End Fault function on fiber port
- Supports 802.3x flow control for full-duplex and backpressure for half-duplex
- Supports loopback test between two devices over fiber link
- Supports remote twisted-pair status monitoring
- Diversified mounting support: desktop, wall, rack-mount chassis, and optional Din-Rail support
- Chassis installation provides central software management and redundant power backup.
- Support wide range of fiber options: multi-mode fiber, single-mode fiber, bi-directional single fiber, and CWDM

Management functions

- Port configuration control and status monitoring
- Supports Jumbo frame conversion
- Packet filtering
- 802.1Q Control between two ports
- Quality of Service (QoS) control for packet traffic
- Supports loopback test
- Supports remote twisted-pair status monitoring, In-band embedded firmware upgrade function, Web-based browsing interface

1.2 Product Panels

The following figure illustrates the front panel and rear panel of the device:

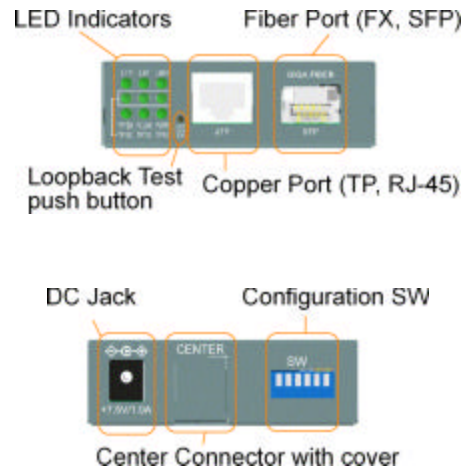

1.3 Specifications

10/100/1000 Twisted-pair Copper Port (TP, RJ-45)

Compliance	IEEE 802.3 10Base-T, IEEE 802.3u 100Base-TX, IEEE 802.3u 1000Base-T
Connectors	Shielded RJ-45 jacks
Pin assignments	Auto MDI/MDI-X detection
Configuration	Auto-negotiation, manual settings or software control
Transmission rate	10Mbps, 100Mbps, 1000Mbps
Duplex support	Full/Half duplex
Network cable	Cat.5 UTP

1000Mbps Fiber Port (FX, Mini-GBIC SFP)

Compliance	IEEE 802.3z 1000Base-SX/LX (mini-GBIC)
Connectors	SFP for optional SFP type fiber transceivers
Configuration	Auto/Forced, 1000Mbps, Full duplex
Transmission rate	1000Mbps
Network cables	MMF 50/125 60/125, SMF 9/125
Eye safety	IEC 825 compliant

Loopback Test Push Button

LOOPBACK TEST	Push button to start loopback test
---------------	------------------------------------

LED Indicators

PWR	Power status
LTP	Local or remote TP indication on TP LEDs
LBT	Loopback test in-progress LED
LBR	Loopback test result LED
FXLNK	Fiber port link and activity status
TP1G	Twisted-pair copper port 1000Mbps and link status
TP100	Twisted-pair copper port 100Mbps and link status
TP10	Twisted-pair copper port 10Mbps and link status
TPFDX	Twisted-pair copper port duplex status

Configuration DIP Switches

SW1-SW3	Twisted-pair copper port configuration
SW4	Flow control setting
SW5	Remote Twisted-pair copper port monitoring
SW6	Link fault pass through function setting

Center Interface

Interface	For 19" rack-mount chassis mounting
Connector	FutureBus

Basic Functions

MAC Addresses	Support up to 8K
Forwarding technology	Store and forward
Maximum packet length	Jumbo frame support up to 8000 bytes
Flow control	IEEE 802.3x pause frame base for full duplex operation Back pressure for half duplex operation

DC Power Input

Interfaces	DC Jack (-D 6.3mm / + D 2.0mm)
Operating Input Voltages	+5 ~ +12VDC(+/-5%)
Power consumption	2.5W max. @ 7.5V

Mechanical

Dimension (base)	4.25 x 2.85 x 0.91 Inches (108 x 72.5 x 23 mm)
Housing	Enclosed metal with no fan
Mounting	Desktop mounting, wall mounting, optional Din-Rail mounting

Environmental

Operating Temperature	Typical -5°C ~ 55°C
Storage Temperature	-20°C ~ 85°C
Relative Humidity	10% ~ 90%

Electrical Approvals

FCC	Part 15 rule Class A
CE	EMC, CISPR22 Class A

Software Management Functions

Interfaces	Web browser
Management objects	System configuration - IP settings, Name, Password Port configuration control and status 802.1Q control settings QoS settings Reboot, restore factory default, update firmware

Models

<u>Special Features</u>	<u>Unmanaged model</u>	<u>Managed model</u>
Configuration DIP SW	Yes	Yes
Link fault pass through	Yes	Yes
Loopback test support	Yes	Yes
Remote TP monitoring	Yes	Yes
Web management	No	Yes
Jumbo frame support	No	Yes
802.1Q Control	No	Yes
QoS Control	No	Yes

2. Installation

2.1 Package Contents

The product package contains:

- Media converter unit
- One product CD-ROM

2.2 Safety Cautions

To reduce the risk of bodily injury, electrical shock, fire, and damage to the product, observe the following precautions.

- Do not service any product except as explained in your system documentation.
- Opening or removing covers may expose you to electrical shock.
- Only a trained service technician should service components inside these compartments.
- If any of the following conditions occur, unplug the product from the electrical outlet and replace the part or contact your trained service provider:
 - The power cable, extension cable, or plug is damaged.
 - An object has fallen into the product.
 - The product has been exposed to water.
 - The product has been dropped or damaged.
 - The product does not operate correctly when you follow the operating instructions.
- Do not push any objects into the openings of your system. Doing so can cause fire or electric shock by shorting out interior components.
- Operate the product only from the type of external power source indicated on the electrical ratings label. If you are not sure of the type of power source required, consult your service provider or local power company.

2.3 Mounting the Media Converter

The media converter can be mounted on a desktop or shelf or a wall. Make sure that there is proper heat dissipation from and adequate ventilation around the device. Do not place heavy objects on the device.

Desktop mounting



Wall mounting

The device has one mounting wall on the bottom side to support wall mounting.

Wall mounting hole
on bottom case

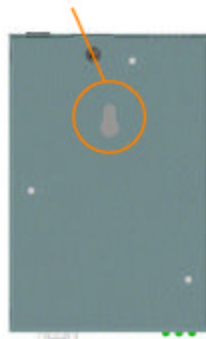

Din-Rail mounting

For a Din-Rail chassis, the device can support mounting on a Din-Rail. An optional Din-Rail bracket, can be purchased separately. The following figure shows an example after bracket installation:

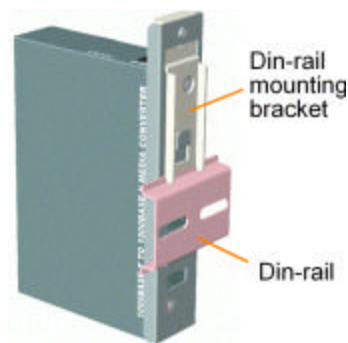

Rack-Mounting

The media converter can also be installed in a 19" rack-mount chassis. The chassis provides the power supply to the converter also with optional power redundancy. Up to 16 units can be installed in one chassis. Unscrew and remove the cover of the center connector before inserting the converter into the chassis. Refer to the operation manual of center chassis for more information.

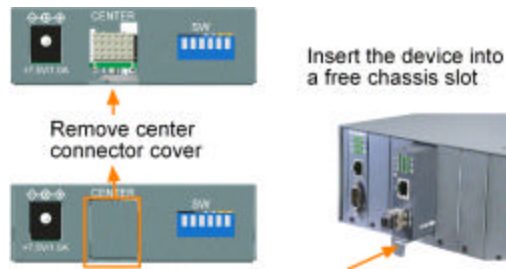

2.4 Applying Power

Before you begin the installation, check the AC voltage of your area. The AC power adapter which is used to supply the DC power for the unit should have the AC voltage matching the commercial power voltage in your area.

The AC Power Adapter Specifications

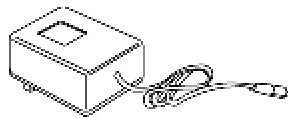

AC input power: AC power voltage of your area, options -
Rated AC120V/60Hz DC7.5V 1A
Rated AC230V/50Hz DC7.5V 1A
Rated AC100V/50-60Hz DC7.5V 1A
Rated AC100V/50-60Hz DC5V 1A
Rated AC240V/50Hz DC7.5V 1A

Steps to apply the power to the device are:

1. Connect power adapter DC plug to the DC input jack located on the back of the unit before connecting to the AC outlet.
2. Connect the power adapter to the AC outlet.
3. Check Power LED indication.

Note: Before you begin the installation, check the AC voltage of your area. The AC power adapter which is used to supply the DC power for the unit should have the AC voltage matching the commercial power voltage in your area.

2.5 Making UTP Connections

The 10/100/1000 twisted-pair copper (TP) port supports the following connection types and distances:

Network Cables

10BASE-T: 2-pair UTP Cat. 3,4,5 , EIA/TIA-568B 100-ohm

100BASE-TX: 2-pair UTP Cat. 5, EIA/TIA-568B 100-ohm

1000BASE-T: 4-pair UTP Cat. 5 or higher (Cat.5e is recommended), EIA/TIA-568B 100-ohm

Link distance: Up to 100 meters

Auto MDI/MDI-X Function

This function allows the port to auto-detect the twisted-pair signals and adapts itself to form a valid MDI to MDI-X connection with the remote connected device automatically. No matter if a straight through cable or crossover cable is connected, the ports can sense the receiving pair automatically and configure itself to match the rule for MDI to MDI-X connection. It simplifies the cable installation.

Auto-negotiation Function

The port is featured with auto-negotiation function and full capability to support connection to any Ethernet devices. The port performs a negotiation process for the speed and duplex configuration with the connected device automatically when each time a link is being established. If the connected device is also auto-negotiation capable, both devices will come out the best configuration after negotiation process. If the connected device is incapable in auto-negotiation, the port will sense the speed and use half duplex for the connection.

Port Configuration Management

For making proper connection to an auto-negotiation CAPABLE device, it is suggested to set port configuration to one of non-auto (forced) operating modes and specify speed and duplex mode which match the configuration used by the connected device.

Two methods for setting copper port configuration are as follows:

<u>Model</u>	<u>Methods</u>
Unmanaged model	DIP SW (switches) SW1, SW2, SW3
Managed model	DIP SW (switches) SW1, SW2, SW3 Software management via web interface <i>Configuration -> Ports -> TP Mode</i>

2.6 Making Fiber Connections

The mini-GBIC SFP (FX) port must be installed with an SFP fiber transceiver for making fiber connections. Your device unit may come with an SFP transceiver pre-installed when it is shipped.

Installing SFP Fiber Transceiver

To install an SFP fiber transceiver into mini-GBIC SFP port, the steps are:

1. Turn off the power to the device unit.
2. Insert the SFP fiber transceiver into the mini-GBIC port. Normally, a bail is provided for every SFP transceiver. Hold the bail and make insertion.
3. Until the SFP transceiver is seated securely in the slot, place the bail in lock position.



Connecting Fiber Cables

LC connectors are commonly equipped on most SFP transceiver modules. Identify TX and RX connector before making cable connection. The following figure illustrates a connection example between two fiber ports:

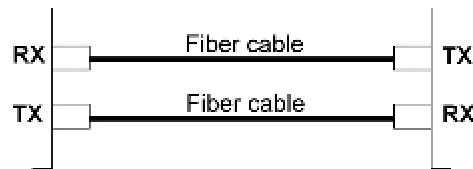

Make sure the Rx-to-Tx connection rule is followed on the both ends of the fiber cable.

Network Cables

Multimode (MMF) - 50/125, 62.5/125

Single mode (SMF) - 9/125

2.7 Loopback Test Push Button

The push button is used to perform loopback test between two media converters connected with fiber cable as shown below:

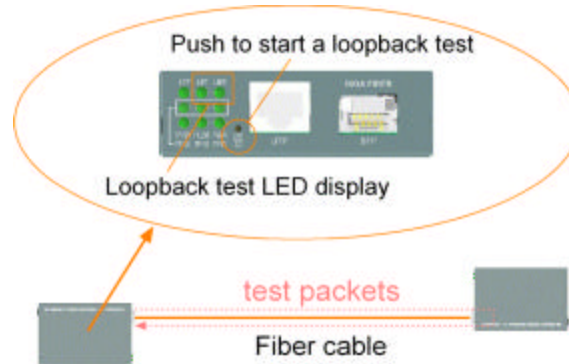

It allows installer to perform diagnostic to the fiber link during installation and check the test result displayed on the LED indicators.

The button may also be used to restore the software configuration settings to factory default values.

The operations are:

Operations	Functions
Press the button and release in normal operation	Perform loopback test over fiber cable
Press the button about 5 seconds when power up	Restore factory default settings

2.8 Configuration DIP SW

The configuration DIP SW (switches) are used for setting operation configuration manually.



The functions of each DIP SW states are:

SW1	SW2	SW3	SW4	SW5	SW6	Function
OFF	OFF	OFF	----	----	----	Ignore DIP SW6 SW5 SW4 settings (Use software configuration for managed model)
ON	OFF	OFF	----	----	----	Set TP Port in non-auto, 10Mbps, Full duplex mode
OFF	ON	OFF	----	----	----	Set TP Port in non-auto, 10Mbps, Half duplex mode
ON	ON	OFF	----	----	----	Set TP Port in non-auto, 100Mbps, Full duplex mode
OFF	OFF	ON	----	----	----	Set TP Port in non-auto, 100Mbps, Half duplex mode
ON	OFF	ON	----	----	----	Set TP Port in auto, 1000Mbps, Full duplex mode
OFF	ON	ON	----	----	----	Dis able TP Port function
ON	ON	ON	----	----	----	Set TP Port in auto, 10/100/1000Mbps, Half/Full duplex
----	----	----	OFF	----	----	Enable flow control
----	----	----	ON	----	----	Dis able flow control
----	----	----	----	OFF	----	Dis able remote TP status auto-report function
----	----	----	----	ON	----	Enable remote TP status auto-report on TP LEDs
----	----	----	----	----	OFF	Dis able Link Fault Pass Through function
----	----	----	----	----	ON	Enable Link Fault Pass Through function

2.9 LED Indication

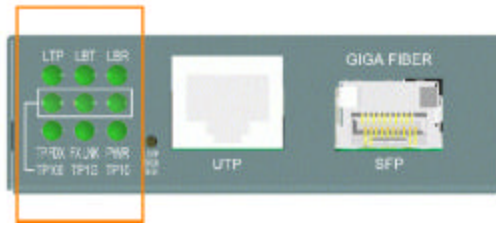

LED	Function	State	Interpretation
PWR	Power status	ON	The power is supplied to the unit.
		OFF	The power is not supplied to the unit.
LTP	Local TP status	ON	Local TP port status displayed on TPxxx LEDs
		OFF	Remote TP port status displayed on TPxxx LEDs
		Blink	Fail to display remote TP port status
<i>Remark: 1. LTP is always ON if remote TP status auto-report function is disabled. 2. When remote TP status auto-report function is enabled, LTP is ON and OFF for ten seconds respectively.</i>			
LBT	Loopback Test	Blink	Loopback Test in operation
		ON	Loopback Test Result is displayed on LBR LED.
		OFF	Loopback Test stops
<i>Remark: 1. LBT blinks to indicate loopback test in operation. 2. LBT is ON for 10 seconds to indicate a test result is displayed on LBR.</i>			
LBR	Loop Back TestResult	ON	Loopback Test OK
		Blink	Loopback Test failed
<i>Remark: 1. LBR display is valid only when LBT is ON. 2. LBR is displayed for 10 seconds to indicate a loopback test result.</i>			
FXLNK	FX port link status	ON	A 1000M link is established on FX port. (No traffic)
		Blink	Port link is up and there is traffic.
		OFF	FX port link is down.
TP1G	TP 1000M link status	ON	A 1000M link is established on TP port.
		OFF	TP port link is down.
TP100	TP 100M link status	ON	A 100M link is established on TP port.
		OFF	TP port link is down.
TP10	TP 10M link status	ON	A 10M link is established on TP port.
		OFF	TP port link is down.
TPHDX	TP duplex status	ON	Full duplex on TP port
		OFF	Half duplex on TP port

2.10 Configuring IP Address and Password for the Device

For managed model, the device unit is shipped with the following factory default settings for software management :

Default IP address of the device : *192.168.0.2 / 255.255.255.0*

The IP Address is an identification of the device unit in a TCP/IP network. Each unit should be designated a new and unique IP address in the network. Refer to Web management interface for System Configuration.

The managed device is shipped with factory default password *123* for software management. The password is used for authentication in accessing to the device via web-based interface. For security reason, it is recommended to change the default settings for the device unit before deploying it to your network. Refer to Web management interface for System Configuration.

3. Functions

To help a better understanding about the software management interfaces, this chapter describes some advanced functions provided by the media converter.

3.1 Abbreviation

TP Port : The twisted-pair copper port of the media converter device.

FX Port : The optical fiber port of the media converter device.

Ingress Port : Ingress port is the input port on which a packet is received.

Egress Port : Egress port is the output port from which a packet is sent out.

IEEE 802.1Q Packets : A packet which is embedded with a VLAN Tag field

VLAN Tag : In IEEE 802.1Q packet format, 4-byte tag field is inserted in the original Ethernet frame between the Source Address and Type/Length fields. The tag is composed of :

<u>#of bits</u>	<u>16</u>	<u>3</u>	<u>1</u>	<u>12</u>
Frame field	TPID	User priority	CFI	VID

TPID : 16-bit field is set to 0x8100 to identify a frame as an IEEE 802.1Q tagged packet

User Priority : 3-bit field refer to the 802.1p priority

CFI : The Canonical Format Indicator for the MAC address is a 1 bit field.

VID : VLAN identifier, 12-bit field identifies the VLAN to which the frame belongs to.

Untagged packet : A standard Ethernet frame with no VLAN Tag field

Priority-tagged packet : An IEEE 802.1Q packet which VID field value is zero (VID=0)

In the device, this packet is also treated as untagged packet.

VLAN-Tagged packet : An IEEE 802.1Q packet which VID field value is not zero (VID<>0)

PVID (Port VID)

PVID is the default VID of an ingress port. It is used in 802.1Q filtering for untagged packets. It is also often used as [Default Tag - VID] for egress tagging operation.

DSCP : Differentiated Service Code Point, 6-bit value field in an IP packet

3.2 Converter Function

The device supports the following data conversions between fiber cable and twisted-pair Cat.5 (copper) cable:

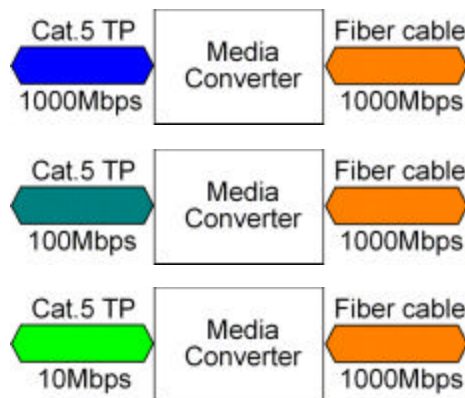

The data rate on twisted-pair segment depends on the link speed finally established with the link partner.

3.3 Link Fault Pass Through Function

Description

When the Link Fault Pass Through (LFPT) function is enabled and the media converter detects a link fault on one port segment, it will force the other port segment link down. It looks like that a link fault is passed from one port to the other.

The following example illustrates a link fault occurs on the fiber cable (any one cable in a duplex fiber connection). The link fault is forwarded to both Gigabit link partners finally by LFPT operation of two media converters.

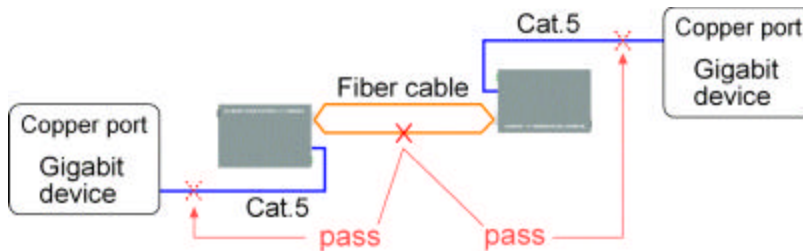

Both Gigabit devices will also detect a link fault on each Cat.5 connection, although the real fault occurs on the fiber connection exactly.

The following example illustrates a real link fault occurs on one Cat.5 and the link fault is passed to the other Cat.5 over two converters and the fiber cable by LFPT operation. Finally, the other link partner also detects a link fault.

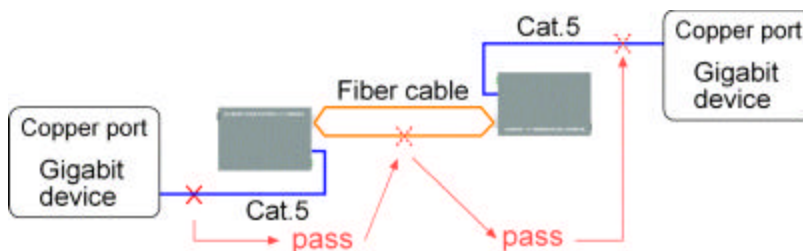

Advantage

The function allows two remote link partners of the media converters detect the link fault finally no matter where the exact fault occurs. It allows the upper application takes necessary action in case a real link fault occurs in any cable segment.

Methods to enable the function

The LFPT function can be enabled by:

- Hardware setting: DIP SW6 is set to ON position
- Software setting: Web management ->
Configuration -> System -> [Link fault pass through]

3.4 Remote TP Status Monitoring Function

Description

The local media converter can monitor the TP port link status of its remote link partner connected on the fiber cable. The status is displayed on the local LED indicators as follows:

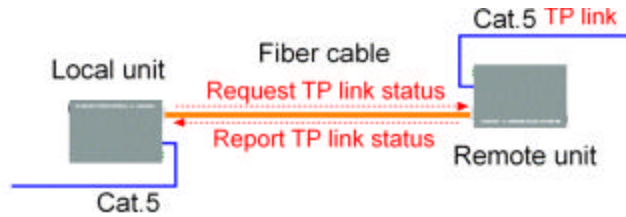

Methods to enable the function

Hardware setting: DIP SW5 is set to ON position

Software setting: Web management ->

Configuration -> System -> [Remote TP auto report]

Remote TP Status Display

1. The status is displayed on local LEDs - TP1G, TP100, TP10, TPFDX when LTP is OFF.

<u>LED</u>	<u>State</u>	<u>Status</u>
LTP	OFF	Remote TP status is valid on the following LEDs
TP1G	ON	Remote TP link in 1000Mbps
	OFF	Remote TP link down
TP100	ON	Remote TP link in 100Mbps
	OFF	Remote TP link down
TP10	ON	Remote TP link in 10Mbps
	OFF	Remote TP link down
TPFDX	ON	Remote TP link in full duplex
	OFF	Remote TP link in half duplex

2. Web management -> *Monitoring -> Statistics -> Remote TP [Link]*

Port	TP	FX	Remote TP
Link	1000FDX	1000FDX	100FDX
Tx Bytes	543184	2066474	-
Tx Frames	3279	9352	-
Rx Bytes	2500054	69168	-
Rx Frames	12539	707	-
Tx Errors	0	0	-
Rx Errors	0	4	-

3.5 802.1Q Control Function

802.1Q Control function allows 802.1Q VLAN related operations to the packets passing through the media converter according packet contents as follows:

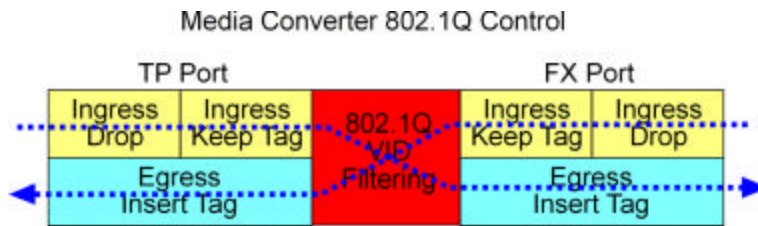

[Ingress Drop] setting

The setting is the first filtering mechanism to filter all incoming untagged packets or to filter all incoming VLAN-tagged packets. The options are:

- Disable* - Disable port ingress drop function
- Untag Only* - All incoming untagged packets and priority-tagged packets are dropped. Only VLAN-tagged packets are admitted.
- Tag Only* - All incoming VLAN-tagged packets are dropped. Only untagged packets and priority-tagged packets are admitted.

[Ingress Keep Tag], [Egress Insert Tag] settings

The settings are used together for packet egress tagging or untagging as table listed below:

<u>Ingress Keep Tag</u>	<u>Egress Insert Tag</u>	<u>Packet Modification</u>
<i>Enable</i>	<i>Disable</i>	All packets are with no modification.
<i>Disable</i>	<i>Disable</i>	All packets are untagged in egress.
<i>Disable</i>	<i>Enable</i>	All packets are tagged in egress.
<i>Enable</i>	<i>Enable</i>	Settings not recommended (possible double-tagging)

[Ingress Keep Tag] options:

- Enable* - The VLAN tag in the received VLAN-tagged packet will be kept as it is and is not stripped in whole conversion operation.
- Disable* - The VLAN tag data in the received VLAN-tagged packet is stripped (removed).

[Egress Insert Tag] options:

- Enable* - Insert a tag into the packet in egress. The tag inserted is based on the rule below:

<u>Incoming Packet Type</u>	<u>Tag inserted</u>
Untagged	Ingress port Default Tag
Priority-tagged	Ingress port Default Tag
VLAN-tagged	Received packet own tag

- Disable* - No tagging is performed.

[Default Tag - VID], [Default Tag - CFI], [Default Tag - Priority] settings

These settings compose one ingress port Default Tag. This tag is used when a tag insertion is required for untagged packets.

802.1Q Filtering

802.1Q VID Filtering function allows to admit or reject certain VID tagged packets. Up to 16 *allowed* (positive list) or *rejected* (negative list) VIDs can be configured. This function allows limiting certain packets to pass from one link segment to another one.

[VID Table] options

Disable - 802.1Q VID filtering is disabled.

Allowed VID - Only the VLAN-tagged packets with VIDs in VID table are admitted.

Rejected VID - The VLAN-tagged packets with VIDs in VID table are rejected and dropped.

For untagged and priority-tagged packets, the ingress [Default Tag - VID], also called PVID is used for VID filtering. If it is in *Allowed VID* table, the untagged packet is allowed to pass; otherwise, dropped. If it is in *Rejected VID* table, the untagged packet is dropped.

3.6 QoS Function

The device provides a powerful Quality of Service (QoS) function to guide the packet forwarding in four priority classes. The versatile classification methods can meet most of the application needs.

The function is useful for guiding the incoming traffic on high data rate port into low data rate port in priority. The following figure illustrates the QoS operation flow when a packet received on the ingress port until it is transmitted out from the egress port:

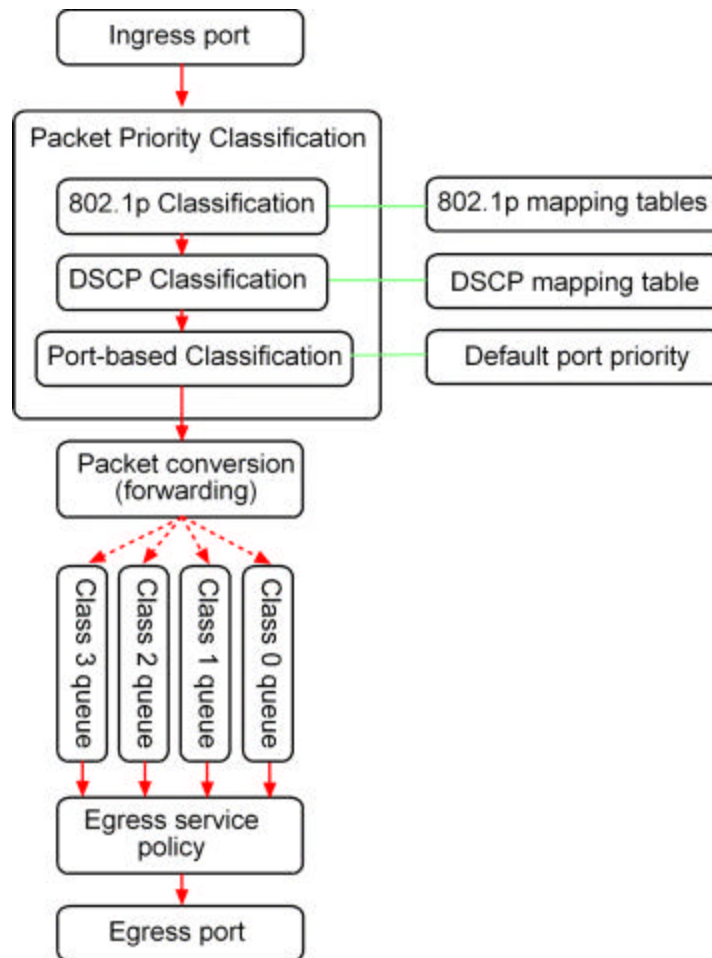

Since the media converter can support full wire speed conversion for 1000Mbps to 1000Mbps, QoS function is not essential for such application. It is suggested to disable the QoS function for 1000Mbps to 1000Mbps conversion.

3.6.1 Packet Priority Classification

Each received packet is examined and classified into one of four priority classes, Class 3, Class 2, Class 1 and Class 0 upon reception. The device provides the following classification methods:

802.1p classification : use User Priority tag value in the received IEEE 802.1Q packet to map to one priority class

DSCP classification : use DSCP value in the received IP packet to map to one priority class

Port-based classification : used when 802.1p and DSCP are disabled or fail to be applied

They all can be configured to be activated or not. More than one classification methods can be enabled at the same time. However, 802.1p classification is superior to DSCP classification.

802.1p mapping tables : Each port has its own mapping table for 802.1p classification.

DSCP mapping table : Two ports share one DSCP mapping table for DSCP classification.

Default port priority : A port default priority class is used when port-based classification is applied

All configuration settings are in per port basis except that DSCP mapping table is global to all ports. A received packet is classified into one of four priority class before it is forwarded to an egress port.

3.6.2 Priority Class Queues

Each port in the device is equipped with four priority class egress queues to store the packets for transmission. A packet is stored into the class queue which is associated to the classified priority class. For example, a packet is stored into Class 3 egress queue if it is classified as priority Class 3.

3.6.3 Egress Service Policy

Each port can be configured with an egress service policy to determine the transmission priority among four class queues. By default, higher class number has higher priority than the lower class numbers.

Four policies are provided for selection as follows:

- **Strict priority** : Packets in high priority class queue are sent first until the queue is empty
- **Weighted ratio priority Class 3:2:1:0 = 4:3:2:1** : four queues are served in 4:3:2:1 ratio
- **Weighted ratio priority Class 3:2:1:0 = 5:3:1:1** : four queues are served in 5:3:1:1 ratio
- **Weighted ratio priority Class 3:2:1:0 = 1:1:1:1** : four queues are served equally

Strict priority policy lets high priority class queue is served first until it is empty. Lower priority queue may not get any service (or egress bandwidth) when higher priority traffic is heavy for long time. Three weighted ratio policies are provided to resolve such problem. Four class queues are served in weighted round robin basis. Every priority class can get a guaranteed ratio for the egress bandwidth.

3.7 SNMP Trap Function

SNMP trap function allows the device to send trap message to an SNMP trap host over SNMP protocol when the associated trap event occurs.

SNMP Trap settings

The settings are used to configure a trap host who can receive the SNMP trap message issued from a media converter device unit.

[SNMP Trap]	Enable / disable SNMP trap function
[Community Name]	The community string bound in a trap message
[Trap IP Address]	The IP address of the target SNMP trap host who is allowed to receive the traps.

SNMP Trap events

The following events are defined for generating a trap message when the event occurs on the unit.

- The device boot up.
- TP copper port link down
- TP copper port link up (link recovery).
- FX fiber port link down
- FX fiber port link up (link recovery).

The following example illustrates an event of FX port link down occurs and is detected by the device. Then, it generates a trap message to the SNMP trap host PC.

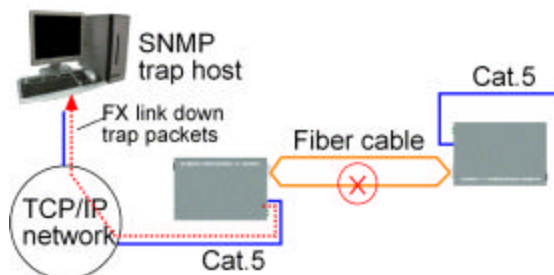

4. Web Management

The M7260M media converter features an http server which can serve the management requests coming from any web browser software over a TCP/IP network.

Web Browser

Compatible web browser software with JAVA script support

Microsoft Internet Explorer 4.0 or later

Netscape Communicator 4.x or later

Set IP Address for the System Unit

Before the device unit can be managed from a web browser, make sure a unique IP address is configured for the unit.

4.1 Start Browser Software and Making Connection

Start your browser software and enter the IP address of the unit to which you want to connect. The IP address is used as URL for the browser software to search the device.

URL : http://xxx.xxx.xxx.xxx/

Factory default IP address : 192.168.0.2

4.2 Login to the Device Unit

When browser software connects to the device unit successfully, a Login screen is provided for you to login to the device as follows:



The device will accept only one successful management connection at the same time. The other connection attempts will be prompted with a warning message.

**Duplicated Administrator
This device is managed by 192.168.0.102
currently!!**

A new connection will be accepted when the current user logout successfully or auto logout by the device due to no access for time out of 3 minutes. *System Configuration* is displayed after a successful login.

4.3 Main Management Menu

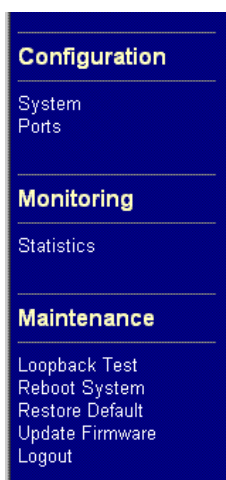

The following information describes the basic functions of the main menu.

Configuration

System	Device information, system and IP related settings
Ports	Port link status, operation mode configuration and other per port settings

Monitoring

Statistic s	List statistics for the local ports and remote TP port link status
-------------	--

Maintenance

Loopback Test	Command to perform loopback test on fiber link
Reboot System	Command to reboot the device unit
Restore Default	Command to restore the device unit with factory default settings
Update Firmware	Command to update the device firmware
Logout	Command to logout from current web management

4.4 System

System Configuration

MAC Address	00-40-16-16-00-02		
S/W Version	1.0		
H/W Version	1.0		
Management VLAN	VID	CFI	User Priority
	<input type="text" value="0"/>	<input type="text" value="0"/>	<input type="text" value="0"/>
IP Address	<input type="text" value="192.168.0.2"/>		
Subnet Mask	<input type="text" value="255.255.255.0"/>		
Gateway	<input type="text" value="192.168.0.1"/>		
Name	<input type="text"/>		
Password	<input type="password" value="•••"/>		
SNMP Trap	<input type="radio"/> Enable <input checked="" type="radio"/> Disable		
Community Name	<input type="text"/>		
Trap IP Address	<input type="text" value="0.0.0.0"/>		
802.1Q Control	<input type="radio"/> Enable <input checked="" type="radio"/> Disable		
QoS Control	<input type="radio"/> Enable <input checked="" type="radio"/> Disable		
Jumbo Mode	<input type="radio"/> Enable <input checked="" type="radio"/> Disable		
Link fault pass through	<input type="radio"/> Enable <input checked="" type="radio"/> Disable		
Remote TP auto report	<input type="radio"/> Enable <input checked="" type="radio"/> Disable		

Configuration	Description
MAC Address	The MAC address factory configured for the unit It can not be changed in any cases.
S/W Version	The firmware version currently running
H/W Version	The hardware version currently operating
Management VLAN	Set management VLAN information (See next section)
- VID	VLAN ID configured for web management to the device
- CFI	CFI value for web reply packets from the device
- User priority	Priority value for web reply packets from the device
IP Address	Set IP address for the device web management
Subnet Mask	Set Subnet mask for IP address for the web management
Gateway	Set Default gateway IP address for the web management
Name	Set the system name for this device unit
Password	Set new password

SNMP Trap	SNMP trap function configuration <i>Disable</i> - the device is disable to send SNMP trap messages. <i>Enable</i> - the device is enable to send SNMP trap messages.
Community Name	Set community string to be bound with trap packets
Trap IP Address	Set IP address of the SNMP trap host
802.1Q Control	802.1Q Control function main configuration <i>Disable</i> - all packets are allowed to pass with no 802.1Q control. <i>Enable</i> - 802.1Q control mechanism is activated for the conversion.
QoS Control	Enable / disable QoS Control function main configuration <i>Disable</i> - Packet priority classification function is disabled. <i>Enable</i> - Packet priority classification function is enabled.
Jumbo Mode	Enable / disable Jumbo mode to support jumbo packets <i>Disable</i> - support maximum packet size up to 1526 bytes <i>Enable</i> - support maximum packet size up to 8000 bytes
Link fault pass through	Enable / disable link fault pass through function
Remote TP auto report	Enable / disable remote TP port link status function

[Apply] Click to apply the configuration change

[Refresh] Click to refresh current configuration

Note: It is suggested to give each device unit a system name as an alternative unique identification besides an IP address.

4.4.1 Management VLAN

Management VLAN settings allow an administrator to access the device and perform the web management over a dedicated VLAN only.

The following rules are applied with the Management VLAN:

1. If the 802.1Q Control function is disabled, Management VLAN settings are ignored and no VLAN limitation is applied in accessing the web management interface. The http server only accepts untagged management packets and replies untagged packets to the management host.
2. If [Management VLAN - VID] settings is zero, no VLAN limitation is applied in accessing the web management interface. The http server only accepts untagged management packets and replies untagged packets to the management host.
3. If [Management VLAN - VID] settings is not zero, The http server only accepts tagged management packets matched [Management VLAN -VID] and replies tagged packets with tag composed of [Management VLAN] VID, CFI and User Priority settings to the management host.

Summary of the rules:

<u>802.1Q Control</u>	<u>Management VLAN VID</u>	<u>Embedded Http (Web) Server operation</u>
Disabled	Ignore	Accept untagged web packets Reply untagged packets
Enabled	VID=0	Accept untagged web packets Reply untagged packets
Enabled	VID<>0 (1 ~ 4095)	Accept matched tagged web packets only Reply tagged packets with the configured tag

Notes:

1. *No matter how management VLAN is configured, login password authentication is still required.*
2. *Default [Management VLAN - VID] is equal to zero. It is allowed to access the device from any untagged PC web browser.*
3. *Most of the PCs are tag-incapable for LAN access. Be sure the rules are followed before setting [Management VLAN - VID] not equal to zero.*

4.5 Ports

Ports Configuration has three major parts as follows:

Port Configuration Port link status, port operating mode, port flow control

802.1Q Control 802.1Q Control per port settings

QoS Control QoS Control per port settings

Port Configuration

Port	TP	FX
Link	1000FDX	1000FDX
Mode	Auto	1000 Full
Flow Control	<input checked="" type="checkbox"/>	<input checked="" type="checkbox"/>

Apply Refresh

802.1Q Control

Port	TP	FX
Ingress Drop	Disable	Disable
Ingress Keep Tag	Enable	Enable
Egress Insert Tag	Disable	Disable
Default Tag - VID(PVID)	1	1
Default Tag - CFI	0	0
Default Tag - Priority	0	0
802.1Q Filtering	Setting	

Apply Refresh

QoS Control

Port	TP	FX
QoS 802.1p	Disable	Disable
QoS DSCP	Disable	Disable
QoS Default Priority	Class 3	Class 3
QoS Egress Service Class 3:2:1:0	Strict priority	Strict priority
QoS 802.1p Mapping	Setting	
QoS DSCP Mapping	Setting	

Apply Refresh

Port Configuration	Function																																																
Port	TP - Twisted-Pair copper port FX - Fiber port																																																
Link	Port link status <i>Speed and duplex status with green background</i> - port is link on <i>Down with red background</i> - port is link down																																																
Mode	Select port operating mode <i>Disabled</i> - disable the port operation <table border="1"> <thead> <tr> <th><u>TP Mode</u></th> <th><u>Auto-negotiation</u></th> <th><u>Speed capability</u></th> <th><u>Duplex capability</u></th> </tr> </thead> <tbody> <tr> <td><i>Disable</i></td> <td><i>Disable port operation</i></td> <td></td> <td></td> </tr> <tr> <td><i>Auto</i></td> <td><i>Enable</i></td> <td><i>10, 100, 1000M</i></td> <td><i>Full, Half</i></td> </tr> <tr> <td><i>10 Half</i></td> <td><i>Disable</i></td> <td><i>10M</i></td> <td><i>Half</i></td> </tr> <tr> <td><i>10 Full</i></td> <td><i>Disable</i></td> <td><i>10M</i></td> <td><i>Full</i></td> </tr> <tr> <td><i>100 Half</i></td> <td><i>Disable</i></td> <td><i>100M</i></td> <td><i>Half</i></td> </tr> <tr> <td><i>100 Full</i></td> <td><i>Disable</i></td> <td><i>100M</i></td> <td><i>Full</i></td> </tr> <tr> <td><i>1000 Full</i></td> <td><i>Enable</i></td> <td><i>1000M</i></td> <td><i>Full</i></td> </tr> </tbody> </table> <table border="1"> <thead> <tr> <th><u>FX Mode</u></th> <th><u>Auto-negotiation</u></th> <th><u>Speed capability</u></th> <th><u>Duplex capability</u></th> </tr> </thead> <tbody> <tr> <td><i>Disable</i></td> <td><i>Disable port operation</i></td> <td></td> <td></td> </tr> <tr> <td><i>1000 Full</i></td> <td><i>Enable</i></td> <td><i>1000M</i></td> <td><i>Full</i></td> </tr> <tr> <td><i>Force 1000 Full</i></td> <td><i>Disable</i></td> <td><i>1000M</i></td> <td><i>Full</i></td> </tr> </tbody> </table>	<u>TP Mode</u>	<u>Auto-negotiation</u>	<u>Speed capability</u>	<u>Duplex capability</u>	<i>Disable</i>	<i>Disable port operation</i>			<i>Auto</i>	<i>Enable</i>	<i>10, 100, 1000M</i>	<i>Full, Half</i>	<i>10 Half</i>	<i>Disable</i>	<i>10M</i>	<i>Half</i>	<i>10 Full</i>	<i>Disable</i>	<i>10M</i>	<i>Full</i>	<i>100 Half</i>	<i>Disable</i>	<i>100M</i>	<i>Half</i>	<i>100 Full</i>	<i>Disable</i>	<i>100M</i>	<i>Full</i>	<i>1000 Full</i>	<i>Enable</i>	<i>1000M</i>	<i>Full</i>	<u>FX Mode</u>	<u>Auto-negotiation</u>	<u>Speed capability</u>	<u>Duplex capability</u>	<i>Disable</i>	<i>Disable port operation</i>			<i>1000 Full</i>	<i>Enable</i>	<i>1000M</i>	<i>Full</i>	<i>Force 1000 Full</i>	<i>Disable</i>	<i>1000M</i>	<i>Full</i>
<u>TP Mode</u>	<u>Auto-negotiation</u>	<u>Speed capability</u>	<u>Duplex capability</u>																																														
<i>Disable</i>	<i>Disable port operation</i>																																																
<i>Auto</i>	<i>Enable</i>	<i>10, 100, 1000M</i>	<i>Full, Half</i>																																														
<i>10 Half</i>	<i>Disable</i>	<i>10M</i>	<i>Half</i>																																														
<i>10 Full</i>	<i>Disable</i>	<i>10M</i>	<i>Full</i>																																														
<i>100 Half</i>	<i>Disable</i>	<i>100M</i>	<i>Half</i>																																														
<i>100 Full</i>	<i>Disable</i>	<i>100M</i>	<i>Full</i>																																														
<i>1000 Full</i>	<i>Enable</i>	<i>1000M</i>	<i>Full</i>																																														
<u>FX Mode</u>	<u>Auto-negotiation</u>	<u>Speed capability</u>	<u>Duplex capability</u>																																														
<i>Disable</i>	<i>Disable port operation</i>																																																
<i>1000 Full</i>	<i>Enable</i>	<i>1000M</i>	<i>Full</i>																																														
<i>Force 1000 Full</i>	<i>Disable</i>	<i>1000M</i>	<i>Full</i>																																														
Flow Control	Set port flow control function V - set to enable 802.3x pause flow control for ingress and egress																																																

802.1Q Control	Function
Ingress Drop	<i>Disable</i> - disable port ingress drop and admit all packet types <i>Untag Only</i> - Drop both untagged and priority-tagged packets <i>Tag Only</i> - Drop VLAN-tagged packets (VID<>0)
Ingress Keep Tag	Tag is removed from the received packet if it exists. <i>Enable</i> - set to activate tag removal for VLAN-tagged packets <i>Disable</i> - set to disable tag removal function
Egress Insert Tag	Tag is inserted into the outgoing packet in egress operation. <i>Enable</i> - set to activate tagging <i>Disable</i> - set to disable tagging function
Default Tag - VID	Port VID, VID for Ingress Default Tag 1 ~ 4095 - decimal 12-bit VID value
Default Tag - CFI	CFI for Ingress Default Tag 0, 1 - 1-bit CFI value
Default Tag -Priority	User priority for Ingress Default Tag 0 ~ 7 - decimal 3-bit value
[802.1Q Filtering]	Click to set VID filtering table

QoS Control	Description
QoS 802.1p	802.1p priority classification <i>Enable</i> - set to enable this classification to the port for priority-tagged and VLAN-tagged packets <i>Disable</i> - 802.1p classification is not applied to the port
QoS DSCP	DSCP classification <i>Enable</i> - set to enable DSCP classification to the port for IP packets <i>Disable</i> - DSCP classification is not applied to the port.
QoS Default Priority	Default priority class, it is used when 802.1p and DSCP classifications are disabled. It is also used as default priority class for the received packet when both 802.1p and DSCP classification failed in classification. <i>Class 3 ~ Class 0</i> - priority class
QoS Egress Service	Service policy for egress priority among four egress class queues <i>Strict priority</i> - high class queue is served first always till it is empty <i>Ratio 4:3:2:1</i> - Weighted ratio priority Class 3:2:1:0 = 4:3:2:1 <i>Ratio 5:3:1:1</i> - Weighted ratio priority Class 3:2:1:0 = 5:3:1:1 <i>Ratio 1:1:1:1</i> - Weighted ratio priority Class 3:2:1:0 = 1:1:1:1
[802.1p Mapping]	Click to configure 802.1p mapping tables.
[DSCP Mapping]	Click to configure DSCP mapping table.
[Apply]	Click to apply the configuration change
[Refresh]	Click to refresh current configuration

Notes:

1. 802.1p classification is superior over DSCP classification if both are enabled. That means if a received packet is classified successfully in 802.1p classification, the classified priority class is used directly for the packet and the result of DSCP classification is ignored.
2. Queue with higher class number has higher priority than queue with lower class number. That means Class 3 > Class 2 > Class 1 > Class 0 by default.
3. In weighted ratio policies, a weighted fairness round robin service is guaranteed normally. However, when excess bandwidth exists higher class queue will take advantage on bandwidth allocation.
4. It is suggested to apply QoS Control function only on 1000M to 100M conversion. Under 1000M to 1000M full wire speed conversion, the effect of QoS control function is not obvious.
5. The function of all three [Apply] buttons are identical. Click any one to apply the change.
6. The function of all three [Refresh] buttons are identical. Click any one to refresh settings.

4.5.1 802.1Q Filtering

802.1Q Filtering

VID TABLE:

No.	VID	No.	VID
1	1	9	9
2	2	10	10
3	3	11	11
4	4	12	12
5	5	13	13
6	6	14	14
7	7	15	15
8	8	16	16

Configuration	Description
VID TABLE	Specify the characteristic of the VID table. <i>Disable</i> - set to disable 802.1Q filtering function. <i>Allowed VID</i> - the VID table specifies the allowed VIDs <i>rejected VID</i> - the VID table specifies the rejected VIDs
No.	Entry of VID table - up to 16 VIDs can be configured in VID table
VID	1 ~ 4095 - decimal 12-bit VID value
[Apply]	Click to apply the configuration change.
[Refresh]	Click to refresh current configuration.
[Close]	Click to close this window.

Notes:

1. VID table is referred for filtering VLAN-tagged packets according to the VID value embedded in the packet. For untagged or priority-tagged packet, [Default Tag - VID], also called PVID is used instead in referring VID table.
2. [Allowed VID] setting is useful when only certain VIDs are allowed to pass the device.
3. [Rejected VID] setting is useful when only certain VIDs are not allowed to pass the device.

4.5.2 802.1p Mapping

QoS 802.1p Mapping

Port	TP	FX
tag 0	Class 0	Class 0
tag 1	Class 0	Class 0
tag 2	Class 1	Class 1
tag 3	Class 1	Class 1
tag 4	Class 2	Class 2
tag 5	Class 2	Class 2
tag 6	Class 3	Class 3
tag 7	Class 3	Class 3

Configuration	Description
---------------	-------------

Port	TP - Twisted-Pair copper port FX - Fiber port
tag m	3-bit User priority tag value m (range : 0 ~ 7)
Priority class	Mapped priority class for tag m on Port <i>Class 3 ~ Class 0</i>

[Apply]	Click to apply the configuration change
[Refresh]	Click to refresh current configuration
[Close]	Click to close the window

Notes:

1. Each port has its own 802.1p mapping table.
2. The ingress port table is referred in 802.1p priority classification for a received packet.

4.5.3 DSCP Mapping

QoS DSCP Mapping

DSCP [0-63]	Priority
<input type="text"/>	Class 0
<input type="text"/>	Class 0
<input type="text"/>	Class 0
<input type="text"/>	Class 0
<input type="text"/>	Class 0
<input type="text"/>	Class 0
<input type="text"/>	Class 0
<input type="text"/>	Class 0
All others	Class 0

Configuration	Description
DSCP [0-63]	Seven user-defined DSCP values which are configured with a priority class 0 ~ 63 - 6-bit DSCP value in decimal
Priority	The priority class configured for the user-defined DSCP value <i>Class 3 ~ Class 0</i>
All others	The other DSCP values not in the seven user-defined values are assigned a default priority class <i>Class 3 ~ Class 0</i>
[Apply]	Click to apply the configuration change
[Refresh]	Click to refresh current configuration
[Close]	Click to close the window

Notes:

1. Only one DSCP mapping table is configured and applied to both ports.
2. The table is referred in DSCP priority classification for a received packet.

4.6 Statistics

Statistics for all ports

Port	TP	FX	Remote TP
Link	1000FDX	1000FDX	100FDX
Tx Bytes	482621	5009373	-
Tx Frames	4771	24317	-
Rx Bytes	5302406	175630	-
Rx Frames	27424	2251	-
Tx Errors	0	0	-
Rx Errors	0	0	-

Configuration	Description
---------------	-------------

Port	TP - Twisted-Pair copper port on local unit FX - Fiber port on local unit Remote TP - TP port of the remote unit connected on the fiber link
Link	Port link status Speed and duplex status with green background - port is link on Down with red background - port is link down
Tx Bytes	Total of bytes transmitted on the port
Tx Frames	Total of packet frames transmitted on the port
Rx Bytes	Total of bytes received on the port
Rx Frames	Total of packet frames received on the port
Tx Errors	Total of error packet frames transmitted on the port
Rx Errors	Total of error packet frames received on the port

[Clear] Click to reset all statistic counters

[Refresh] Click to refresh all statistic counters

4.7 Loopback Test

Loopback Test

Are you sure you want to perform Loopback Test?

This menu is used to start a loopback test operation with the link partner unit over the fiber link. The message displayed during test is:

Loopback Test

TESTING NOW : 10 %

The result message displayed after a test finished is:

Loopback Test

TESTING RESULT : OK!!

The test result is also displayed on LEDs - LBT and LBR.

4.8 Reboot System

Reboot System

Are you sure you want to reboot system?

This menu is used to reboot the device unit remotely with current configuration. Starting this menu will make your current http connection lost. You must rebuild the connection to perform any management operation to the unit.

4.9 Restore Default

Restore Default

Are you sure you want to restore factory default?

This menu is used to restore all settings of the device unit with factory default values. Note that this menu might change the current IP address of the device and make your current http connection lost.

4.10 Update Firmware

Update Firmware



The screenshot shows a web interface for updating firmware. At the top, the title 'Update Firmware' is displayed in blue. Below it is a text input field for the file path, followed by a '浏览...' (Browse...) button. Below the input field is an 'Upload' button.

This menu is used to perform in-band firmware (software) upgrade. Enter the path and file name of new firmware image file for uploading.

Configuration	Description
Filename	Path and filename (warp format)
[Browse]	Click to browse your computer file system for the firmware image file
[Upload]	Click to start upload

4.11 Logout

Logout

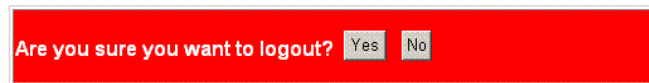

The screenshot shows a red confirmation dialog box with the text 'Are you sure you want to logout?' and two buttons: 'Yes' and 'No'.

This menu is used to perform a logout from the web management. If current user does not perform any management operation over 3 minutes, the device will execute an auto logout and abort the current connection.

Appendix A. Factory Default Settings

Configuration DIP SW	Unmanaged Mode I	Managed Mode I
SW3 SW2 SW1	<i>ON ON ON</i>	<i>OFF OFF OFF</i>
	<i>Auto, 10/100/100, Full/Half</i>	<i>Web configuration (SW4-6 ignored)</i>
SW4	<i>OFF (Enable flow control)</i>	<i>OFF</i>
SW5	<i>OFF (Disable remote TP auto report)</i>	<i>OFF</i>
SW6	<i>OFF (Disable link fault pass through)</i>	<i>OFF</i>

System Configuration

Management VLAN - VID	<i>0</i>
Management VLAN - CFI	<i>0</i>
Management VLAN - User priority	<i>0</i>
IP Address	<i>192.168.0.2</i>
IP Subnet mask	<i>255.255.255.0</i>
Gateway IP	<i>192.168.0.1</i>
Name	<i>Null</i>
Password	<i>123</i>
SNMP Trap	<i>Disable</i>
Community Name	<i>Null</i>
Trap IP Address	<i>0.0.0.0</i>
802.1Q Control	<i>Disable</i>
QoS Control	<i>Disable</i>
Jumbo Mode	<i>Disable</i>
Link fault pass through	<i>Disable</i>
Remote TP auto report	<i>Disable</i>

Ports Configuration

Mode	<i>Auto for TP port, 1000 Full for FX port</i>
Flow Control	<i>v : Enable</i>
Ingress Drop	<i>Disable</i>

Ingress Keep Tag	<i>Enable</i>
Egress Insert Tag	<i>Disable</i>
Default Tag - VID (PVID)	<i>1</i>
Default Tag - CFI	<i>0</i>
Default Tag - Priority	<i>0</i>
QoS 802.1p	<i>Disable</i>
QoS DSCP	<i>Disable</i>
QoS Default Priority	<i>Class 3</i>
QoS Egress Service	<i>Strict priority</i>

802.1Q Filtering

VID TABLE	<i>Disable</i>
VID n (n=1-16)	<i>n</i>

802.1p Mapping

tag 0	<i>Class 0</i>
tag 1	<i>Class 0</i>
tag 2	<i>Class 1</i>
tag 3	<i>Class 1</i>
tag 4	<i>Class 2</i>
tag 5	<i>Class 2</i>
tag 6	<i>Class 3</i>
tag 7	<i>Class 3</i>

DSCP Mapping

DSCP / Priority 1 -7	<i>Null / Class 0</i>
All others	<i>Class 0</i>

Appendix B. Models & Optical Specifications

Model Description

M7260M Managed model without SFP transceiver module

AVAILABLE SFP MODULES				
<u>MODEL</u>	<u>FIBER</u>	<u>WAVELENGTH</u>	<u>CONNECTOR</u>	<u>DISTANCE</u>
GBMM	Multimode SX (62.5/125) Multimode SX (50/125)	850nm 850nm	LC LC	200 m 500 m
GB10SM	Multimode LX Singlemode LX	1310nm 1310nm	LC	550m 10 Km
GB20SM	Singlemode LX	1310nm	LC	20 Km
GB40SM	Singlemode LX	1550nm	LC	40 Km
GB70SM	Singlemode LX	1550nm	LC	70 Km
GB10SFA	Singlemode LX	Tx: 1310nm Rx: 1550nm	LC	10 Km
GB10SFB	Singlemode LX	Tx: 1550nm Rx: 1310nm	LC	10 Km
GB20SFA	Singlemode LX	Tx: 1310nm Rx: 1550nm	LC	20 Km
GB20SFB	Singlemode LX	Tx: 1550nm Rx: 1310nm	LC	20 Km
GB40SFA	Singlemode LX	Tx: 1310nm Rx: 1550nm	LC	40 Km
GB40SFB	Singlemode LX	Tx: 1550nm Rx: 1310nm	LC	40 Km
GB40SFCxx	Singlemode LX	Tx: xx = 1xx0nm Rx = 1100-1650nm	LC	40 Km
GB80SFCxx	Singlemode LX	Tx: xx = 1xx0nm Rx = 1100-1650nm	LC	80 Km